

ProtoPixel Software Suite

User Manual

(ENG)

Project Tool User Manual
and Mapping Tool User Manual

ProtoPixel Project Tool

User Manual

Contents

01	Setup		06	Manage Spaces	
	System Requirements	04		Managing Spaces	27
	Download Project Tool	04			
02	Getting Started		07	Moods	
	Create an account on My ProtoPixel	06		Creating a Mood	29
	Log-in using a My ProtoPixel account	06		Edit or delete a Mood	29
	Access to a ProtoPixel Brain	07			
	ProtoPixel Gate DALI Wired Configuration	08	08	Behaviours	
	Create a New Installation	09		Create a behaviour for a Button	31
	Getting to know Project Tool's UI	10		Create a behaviour for a Occupancy Sensor	32
03	Using the floorplan	15	09	Scheduler	
	Setting up the floorplan	16		Configure your scheduler	
	Navigating your floorplan			Create an event	34
				Scheduler viewing options	35
04	Gateways and integrations	18			36
	Connect to ProtoPixel Gate DALI Wired	18			
	Discover and include elements in your Network	19			
	Import Mapping Tool projects				
05	Elements management	21			
	Locate elements	21			
	Place elements in the floorplan	22			
	Control your luminaires	23			
	Replace elements	25			
	Remove elements				

ProtoPixel Project Tool is a software tool designed to plan and set up lighting projects. It takes into account the physical space and Project Tools different technologies, while remaining technology

01 Setup

01	Setup	
	System Requirements	04
	Download Project Tool	04

01

Setup

System Requirements

ProtoPixel Project Tool is compatible with Windows 8 or superior, Mac OS 12 or superior, and Ubuntu. You will need at least one ProtoPixel Brain with 22.11 software version or greater, and one ProtoPixel ProtoPixel Gate DALI Wired. Finally, luminaires, sensors and switches compliant with DALI2 protocol.

Downloading Project Tool

In order to download Project Tool, you'll need to register and [log in to MyProtoPixel](#). Then, head to the Downloads tab and download the latest version of Project Tool for the operating system you use (Windows, macOS, or Linux). You'll always see the last version of Project Tool at the top of the page. Make sure you download the right version.

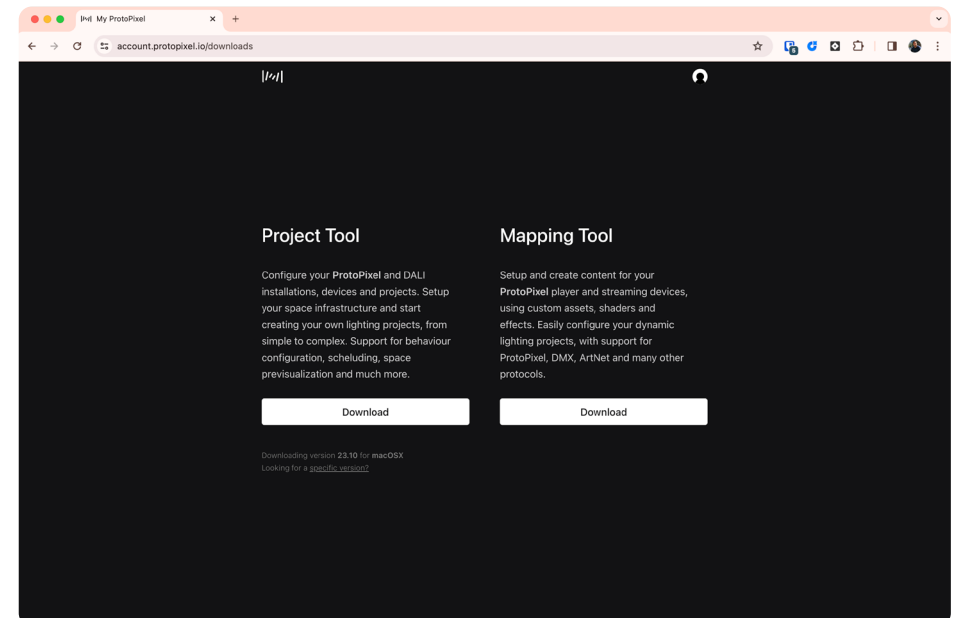

02 Getting Started

02	Getting Started	
	Create an account on My ProtoPixel	06
	Log-in using a My ProtoPixel account	
	Connect to a ProtoPixel Brain	07
	ProtoPixel Gate DALI Wired Configuration	08
	Create a New Installation	09
	Getting to know Project Tool's UI	10
	Working with a Floorplan	11

02

Getting Started

Create an account on My ProtoPixel

To get started, you have two options: create an account and login using your Google account credentials, or create an account using your email address and set a password. Click on “Use email and password” to create an account using your own credentials.

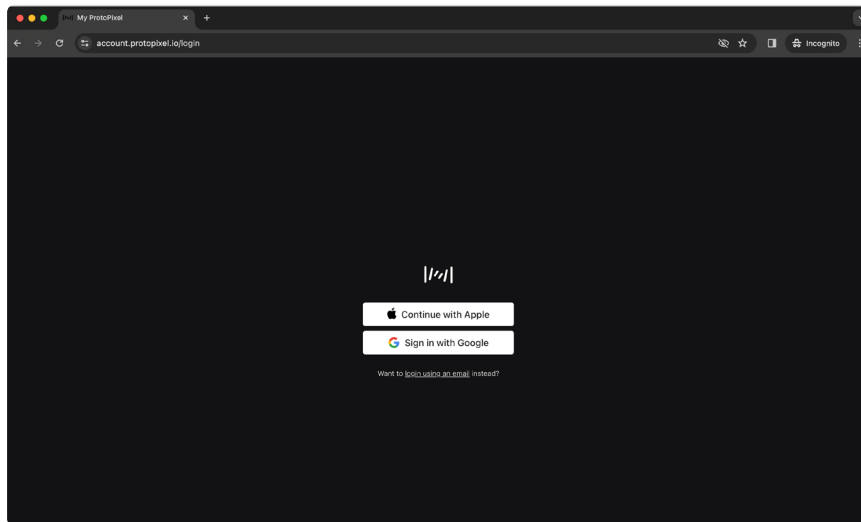

Log-in using a My ProtoPixel Account

Click on “Sign me Up” to create your account. Enter your email address and click on “Sign Up”. Next, create your password, which should include 8 characters, with at least 1 number and 1 capital letter for security reasons. Finally, you will need to agree to the Privacy Policy and Terms of Use. You can also choose whether you would like ProtoPixel to send you emails with news about future launches and all of our activities. Then click “Sign Up”. In order your account to be confirmed, you’ll need to go to your inbox and confirm your address with an email that we’ll send you.

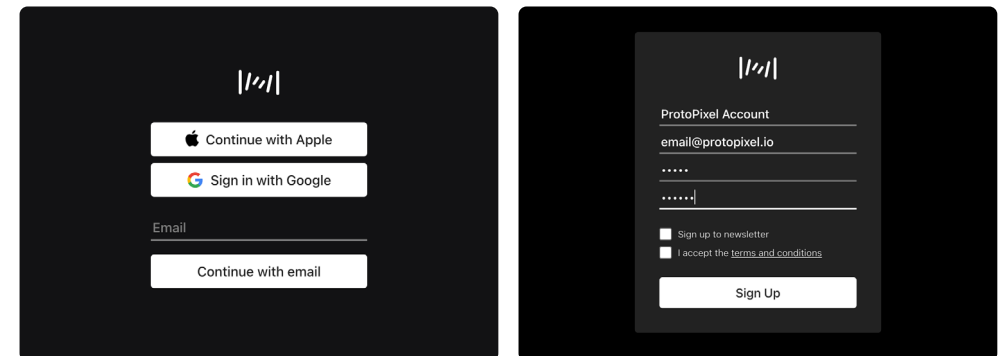

02

Connect to ProtoPixel Brain

Access a ProtoPixel Brain

Once you have logged in using your MyProtoPixel account, you will land in the welcome view of Project Tool. In this view, you will be able to see all the ProtoPixel Brains that are connected to the network you are in. To access the installation running on a ProtoPixel Brain or create a new one click on the ProtoPixel Brain you want to access from the list. Make sure you are on the same network as the ProtoPixel Brain you are trying to reach.

Disconnect from a ProtoPixel Brain

If, for some reason, a ProtoPixel Brain that you had previously accessed is no longer reachable, you'll see an alert icon next to it. You should check your laptop and/or ProtoPixel Brain connection.

In order to disconnect from a ProtoPixel Brain, you need to go to **“File”** and then **“Disconnect from ProtoPixel Brain”**. You will be headed back to the ProtoPixel Brains list. You can learn more about ProtoPixel Brain configuration [here](#).

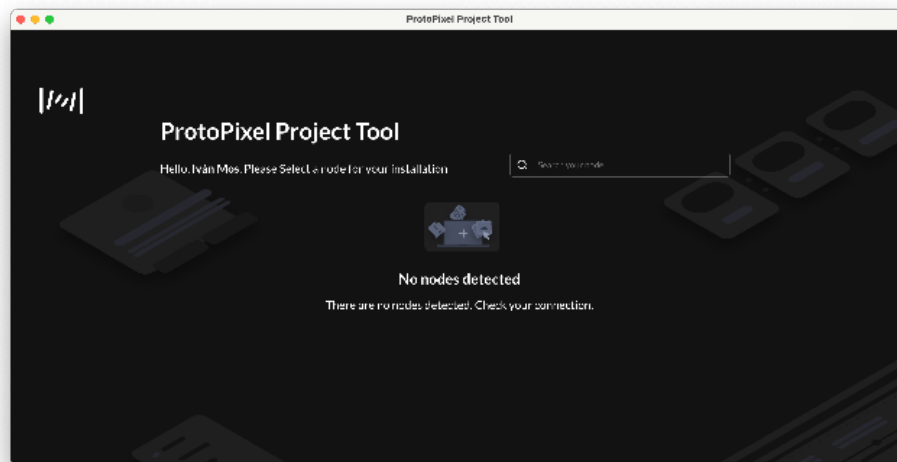

02

ProtoPixel Gate DALI Wired

Configuring ProtoPixel Brain

The ProtoPixel Gate DALI Wired needs to be manually set up and connected to a ProtoPixel Brain. To do so, first assign a static IP of 192.168.11.254 to the ProtoPixel Brain using the ProtoPixel Brain web application.

Setting up the ProtoPixel

To set up the device, use two rotating switches to assign a static IP address within the range of 192.168.11.1-192.168.11.79. The first rotating switch sets the last digit of the IP address and can be configured between 1-79. Note that a value of 0 is not supported, as it sets the Gateway to DHCP configuration.

Connecting to Project Tool

Open the ProtoPixel Project Tool and click on "Discover Gateways". This will display all the ProtoPixel Gate DALI Wired devices found on the network.

Important

For the ProtoPixel Gate DALI Wired to communicate with the ProtoPixel Brain, the ProtoPixel Brain's IP address must be set to 192.168.11.254.

dhcp_enabled	<input checked="" type="checkbox"/>
static_enabled	<input checked="" type="checkbox"/>
fixed_ip	192.168.11.254
fixed_mask	255.255.255.0
fixed_gateway	0.0.0.0
wifi_AP_enabled	<input checked="" type="checkbox"/>
wifi_ssid	ppxnode-35C3E04
wifi_password	••••••••

Change

ProtoPixel Brain Network
Configuration UI

02

ProtoPixel Gate DALI Wired

Changing the IP

To change the IP of the ProtoPixel Gate DALI Wired, follow these steps:

1. Connect your laptop directly to the gateway using an Ethernet cable.
2. Make sure that the IP address of your laptop matches the IP address of the ProtoPixel Gate DALI Wired.
3. Perform this process outside of the Project Tool. Open the terminal on your laptop.
4. Copy and paste the following text into the terminal, replacing the placeholder values with your own values:

GREEN: Here, you need to put the desired IP address that you want to replace the current one with.

PURPLE: This should be the IP address of your router.

BLUE: This should be the IP address of the ProtoPixel Brain.

BROWN: We recommend putting “static” here to have a static IP.

OLIVE: This is the current IP of the gateway.

After copying and pasting the code and replacing the values in the terminal, press Enter. If everything goes as expected, you will receive a “status 200” and the ID of the ProtoPixel Brain.

```
curl -X POST -H "Content-Type: application/json" -d "{ \"child\": 0, \"data\": { \"deviceIp\" :  
  \"192.168.11.12\", \"deviceMask\" : \"255.255.255.0\", \"deviceGw\" : \"192.168.11.1\", \"brokerUrl\" :  
  \"192.168.11.254\", \"brokerPort\" : 1883, \"brokerTls\" : false, \"brokerMdns\" : \"none\", \"ethMode\"  
  : \"static\", \"resetDefault\" : false } }" http://192.168.11.23:8000/config
```

02

Broadcast to a ProtoPixel Gate DALI Wired

Sending Broadcast Commands to a ProtoPixel Gate DALI Wired

To ensure proper connection of all luminaires, you can use the “Broadcast gateway DALI” feature to check the installation. To send a broadcast to all the luminaires of a ProtoPixel Gate DALI Wired, follow these steps:

1. Go to the “Discovery” section.
2. Click on the desired gateway.
3. Find the “Broadcast” option on the inspector panel.

Here, you have different options. You can send the “All on” or “All off” command to all the elements or only to the unaddressed ones. To send the order and activate or deactivate the selected elements, click on “Send broadcast” after choosing the desired elements and command.

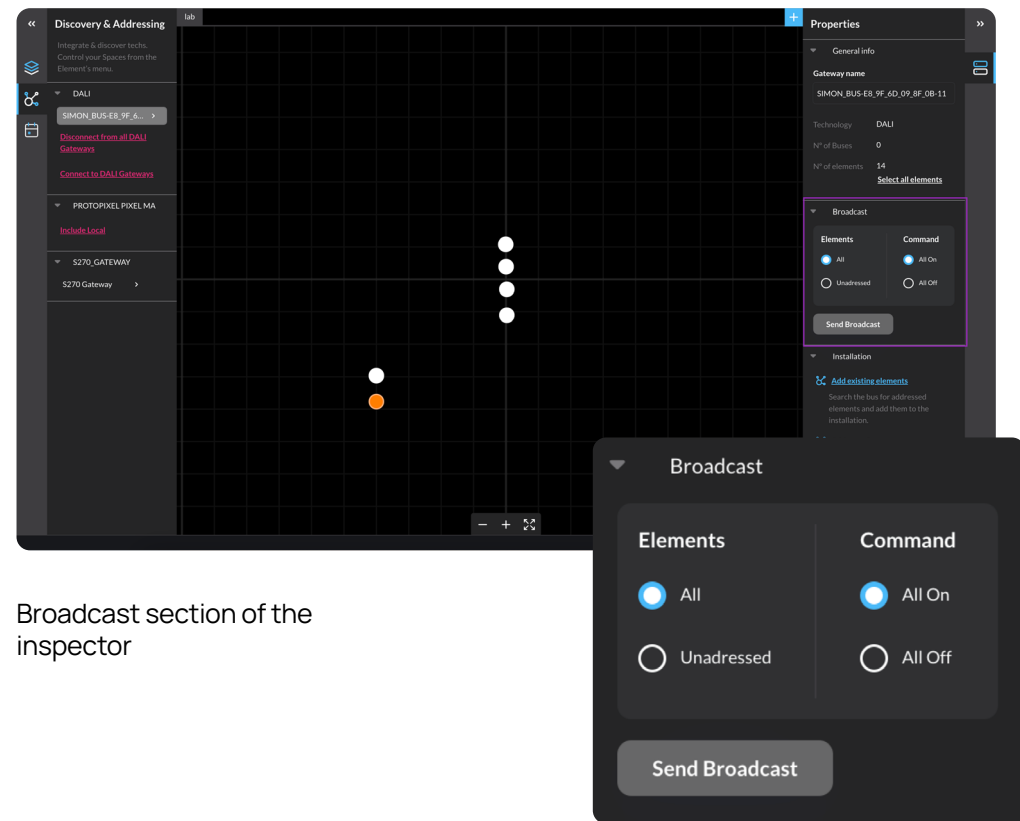

Broadcast section of the inspector

02

Create an Installation

Create a New Installation

When you select a ProtoPixel Brain and there is no installation running on it, you'll need to create a new installation. As soon as you enter the ProtoPixel Brain you'll be asked to name your new installation. Once you enter the name, click "**Continue**". Next, you will be asked to upload a dxf file to work as your floorplan or continue with an Empty canvas.

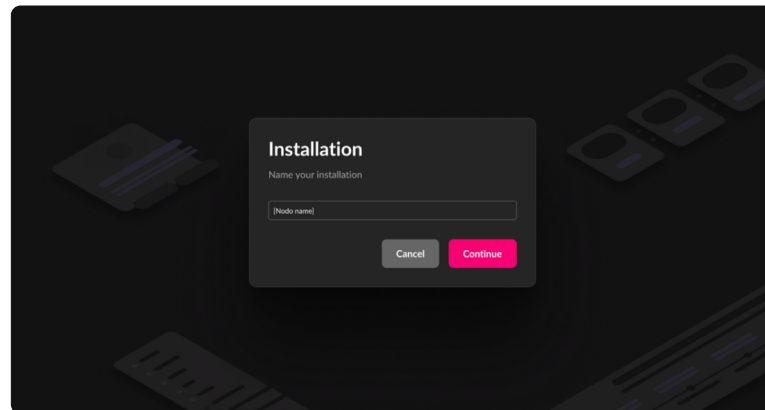

Without a Floorplan

After logging in and selecting a ProtoPixel Brain, you can either select an existing project or start a new one. To start a new project, provide a name for it and confirm by clicking on **Continue**. A new window will appear, where you can either upload a DXF file or select to start with an empty space by choosing **Empty view**. Continue without a DXF file.

Using a Floorplan

Refer to **Setting up your floorplan** (page 15).

02

Getting to know Project Tool's UI

Project Tool's UI is composed of 11 main items:

Item	Part
1	Left SideBar
2	Elements & Spaces
3	Gateways & Integrations
4	Scheduler
5	Canvas
6	Tools: Zoom in, Zoom out, Expand All
7	Floorplan Tapbar
8	Installation Name
9	Floorplans Navigation
10	Top Menu Items
11	Right SideBar
12	Status Bar

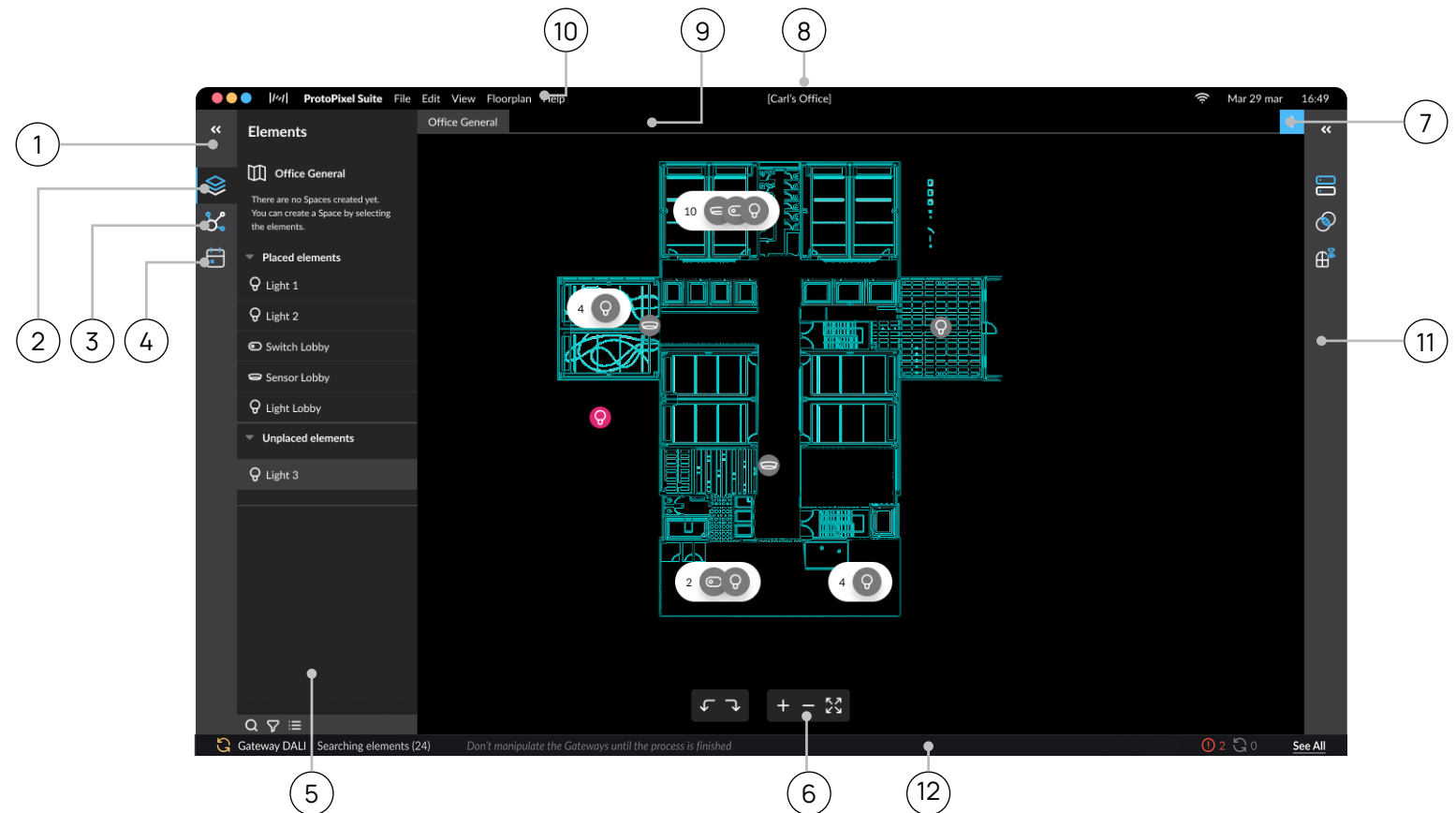

02

Canvas

Every tab is a different floor plan. And the elements included on the elements' list are placed on the Floor plan the user has selected. You can add all the floor plans you need. Floorplans can't share elements. All the canvas configuration is on the Top Menu.

Left Sidebar

As you use the software, you will see two sidebars: one on the right and one on the left. The left sidebar is always visible and displays the following Features:

a. Elements

Here you can see the list of elements you have on your installation, divided by Spaces and by placed and unplaced elements. You can also view all the spaces you have created. Spaces group elements and allow you to send context control commands, such as moods and CLC. On element's list, you'll be able to see if any of the Spaces have an enabled CLC.

b. Discovery

On the discovery menu you will be able to discover all the ProtoPixel Gate DALI Wired and elements included in your installation.

c. Scheduler

Here's the menu item to access to the Scheduler. You can see all the information of this feature on the Scheduler Section.

Status Bar

The status bar is the part that displays ongoing background processes. It provides information about processes that may take a few moments to complete. The status bar keeps you informed about tasks such as saving moods, starting scheduler events, and addressing connectivity issues.

Right Sidebar

Sidebar right will appear when a selected item has properties to show, such as moods (A Space Property). Right sidebar can display following Features:

d. Properties

All element, gateway or Space will show a summary of it's capabilities or

e. Moods

You can see all the information of this feature on the Moods section. Moods feature will be visible when you are on a Space context (you'll be on the Space context if you selected a Space on the Element's list or one of it's elements on the list, not on the floorplan).

f. CLC – Constant Light Control

You can see all the information of this feature on the CLC section. CLC feature will be visible when you are on a Space context (you'll be on the Space context if you selected a Space on the Element's list or one of it's elements on the list, not on the floorplan).

02

Working with a Floorplan

Floorplan Properties

1. Click on Edit - Floorplan, then the floorplan properties screen will pop up.
2. If you want to change the Floorplan / stencil color, click on the Color selector.
3. (Color Square) and the Color selector will be opened.
4. You can also change the opacity of the .dxf file on the canvas.

Floorplan Properties Modal

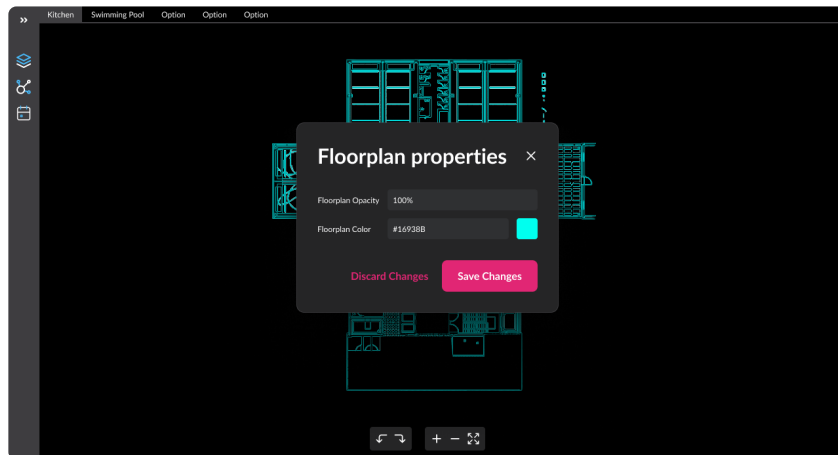

Floorplan Color Selector

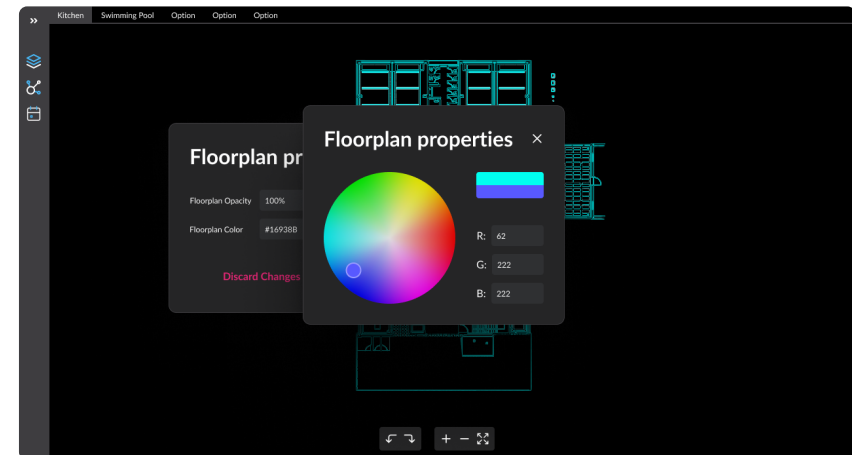

View / Hide Floorplan layers

To view or hide the floor plan layers, click on “View” in the top menu and select “View Floor plan Layers.” A floating panel will be displayed with the floor plan layers, which you can hide or show as needed

Floorplan Layers modal



Add new Floorplan

You can have as many Floor plans as you need. You can add it by click on **Top menu / Edit / Add Floorplan** or with the **plus (+) button** at the top right corner.

Delete Floorplan

This action **can't be undone**. All elements placed on this Floor plan will go to the Unplaced elements folder . All Spaces and moods configured here will be deleted.

You can delete the floorplan if you:

1. Are at the floor plan you want to delete
2. Click on top menu / Edit / Delete Floorplan
3. Click on Button Delete Floorplan

Canvas

Every tab is a different floor plan. And the elements included on the elements' list are placed on the Floor plan the user has selected. You can add all the floor plans you need. Floor plans can't share elements. All the canvas configuration is on the Top Menu.

03 Using the Floorplan

03	Using the floorplan	
	Setting up the floorplan	15
	Navigating your floorplan	16

03

Setting up your Floorplan

Using a .DXF file

When starting a new project or opening a new, secondary, floor plan, you have the option to either utilize a DXF file or have no stencil on your canvas. Upload a DXF file by clicking on “upload” or drag your file into the square dashed pattern. Next, you will have the option to select the desired scale. If you do not make any changes, the document’s original scale will be used by default. If you wish to adjust the scale, you can turn off the “Original Scale” switch. Doing so will provide you with options to configure the units per measurement unit. You have the flexibility to decide whether to display a grid on your canvas and customize the measurement of the grid squares and the unit used. If you want to hide the grid on your canvas, simply turn off the Grid Switch.

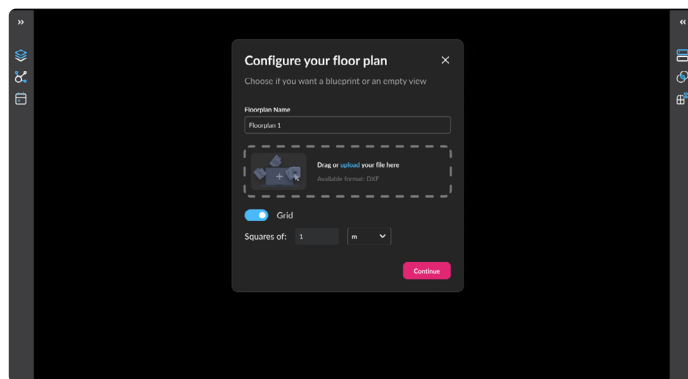

Configuring your Floor Plan

1. Modify Floorplan Name
2. Upload file: Drag and drop, or Upload from Files
3. Select Scale and Units (If Needed)
4. Activate Grid
5. Choose Grid Size and Units (If Needed)

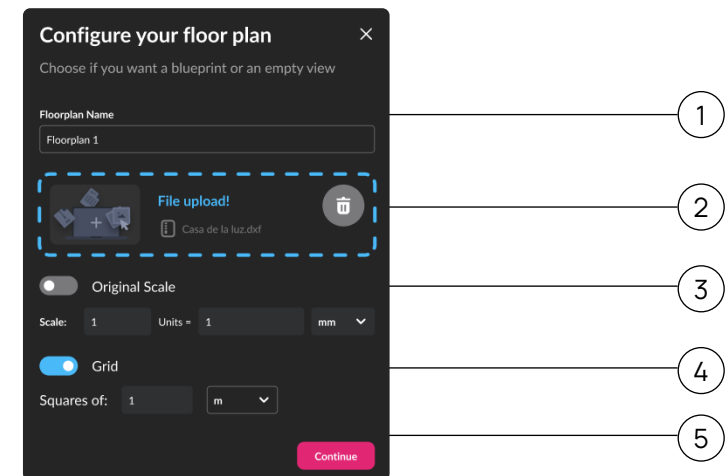

03

Navigating your Floorplan

Place elements on the floor plan

To place elements onto your floor plan, you can simply drag and drop an element from the Elements list to the desired location on your canvas.

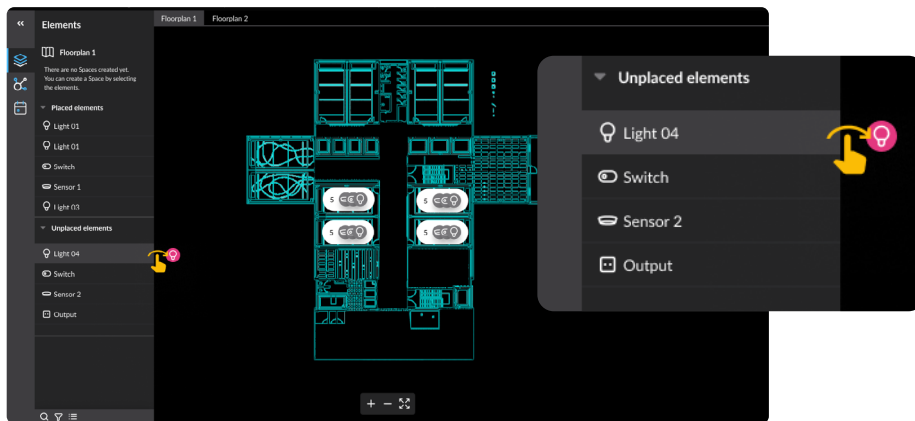

Canvas Panning

To navigate through your canvas, you can press the spacebar on your keyboard. As you do so, your cursor will change to a hand icon, allowing you to drag the canvas and move around freely.

Unplace elements

You have the option to remove elements from the floor plan that you have already added. To do so, follow these steps: locate the element on the floor plan, right-click on it, and choose the “Remove from floor plan” option. This will move the element back to the list of unplaced elements. You can place it back on the floor plan whenever you need it. Keep in mind that if you remove an element that is part of a Space, it will also be removed from the Space.

Zoom In - Zoom Out

To zoom in or out on your canvas, you have access to two floating buttons located at the bottom of the screen. Clicking the “+” button allows you to zoom in, while clicking the “-” button enables you to zoom out. Alternatively, you can also use your trackpad or mouse to zoom in or out by scrolling. When you zoom out, you’ll notice that elements close to each other will group together in visual clusters. It’s important to note that these clusters are purely visual elements designed to enhance the organization of your floor plan and do not represent functional groups or spaces.

Zoom In - Zoom Out

To quickly visualize your entire floor plan, you can click on the “Zoom to Fit” button. This action will zoom out the canvas to ensure that the entire floor plan fits within the screen.

Control

You have complete control over all your elements directly from the Project Tool feature. When you select an element from either the Elements list or the floor plan, you will immediately see its corresponding control options displayed on the Inspector panel.

04 Gateways and Integrations

04	Gateways and Integrations	
	Connect to ProtoPixel Gate DALI Wired	18
	Discover and include elements in your Network	18
	Project Tool with ProtoPixel Mapping Tool	19

04

Connecting to ProtoPixel Gate DALI Wired

Connect to a ProtoPixel Gate DALI Wired

To connect to the different buses in your installation, navigate to the “Discovery & Addressing” panel and click on the “Connect to ProtoPixel Gate DALI Wired” option. Immediately after clicking on “Connect to ProtoPixel Gate DALI Wired,” the connection process will initiate. You have the option to Stop it at any time.

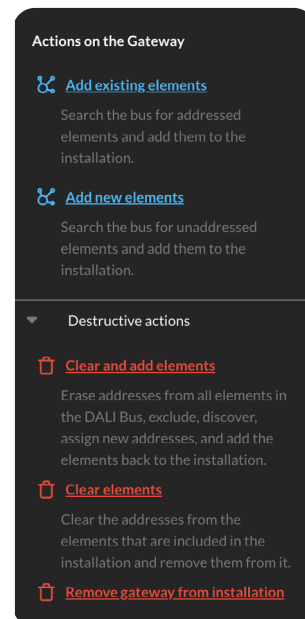

Discover and Include Elements in your Network

Discover all the elements on your installation

Once you have your buses visible on the Discovery & Addressing panel, you can click on the “Include all devices” option to initiate the discovery process. As it progresses, you will observe the number of devices being discovered. Once the process is complete, the “Continue” button will become active. Upon clicking it, you will be able to see the list of all the elements in your installation.

On only one bus

If you wish to discover only the elements of a specific bus, you need to click on that particular bus on the Discovery & Addressing panel. Then, you'll have different options to add and address elements:

- 1. Search for new elements**
Add new elements that have not yet been addressed.
- 2. Readdress elements**
Remove all elements from the Gateway, delete their addresses, and start a new addressing process.
- 3. Search addressed elements**
Search and include already addressed elements.
- 4. Delete all elements**
Delete all elements addresses and remove them from the Gateway.

04

Managing Simon iO 270 buttons in an installation

Include Simon iO 270 buttons to an installation

You can now include Simon iO 270 button boxes in your ProtoPixel Project Tool installation. To do this, you will need to have the ProtoPixel App. You can download it [here](#).

First, open the ProtoPixel App and access the installation where you want to include your iO 270 button box. Then, open the menu and navigate to "Edit installation". From there, click on the "Add new element" button.

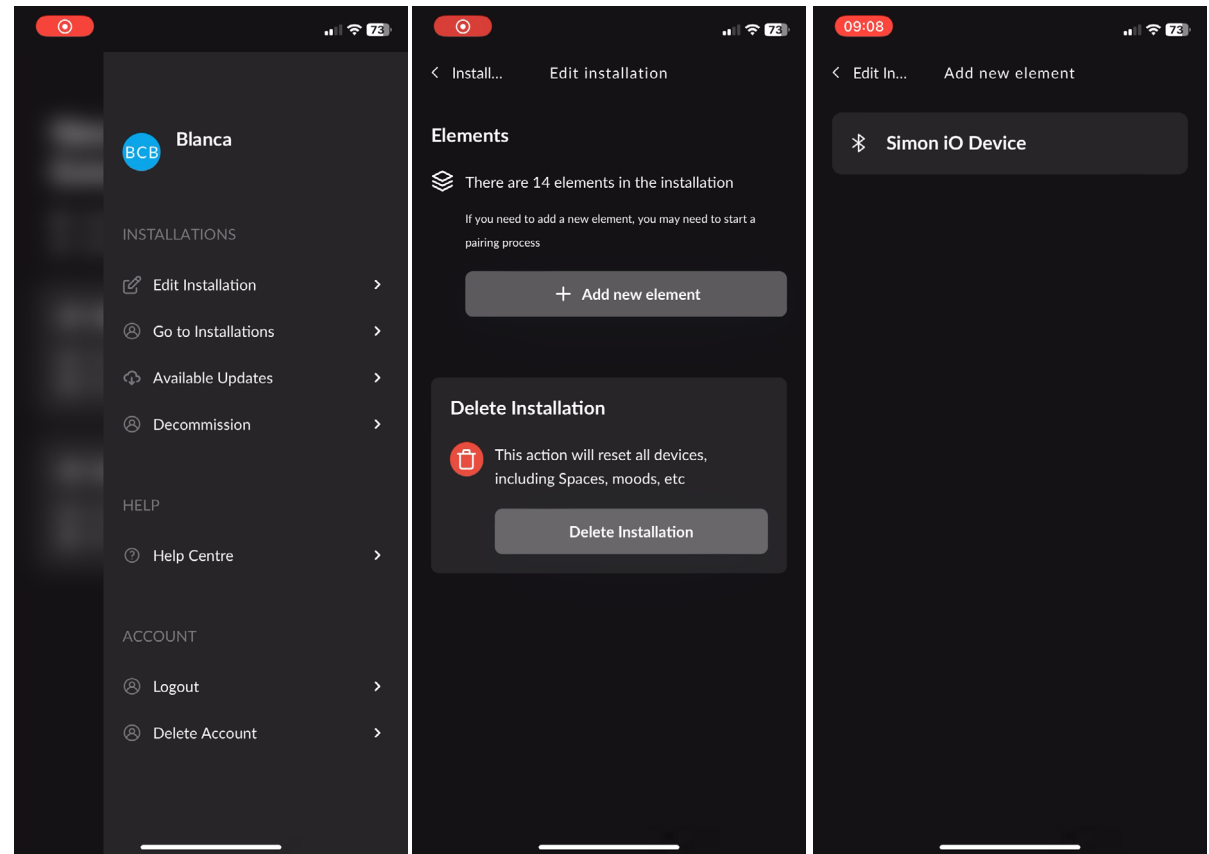

04

Pair with Simon iO 270

To make your Simon iO 270 device discoverable, press one of the buttons until the LED indicator starts blinking rapidly. Then, click on "Simon iO Device". The search process will begin. Ensure that your phone's Bluetooth is turned on and that the Simon iO Device is nearby and turned on.

Once added, you will be redirected to the main installation screen. You will then see the new elements listed in both the ProtoPixel Project Tool and ProtoPixel App.

Now, you can start adding Behaviours to the new element.

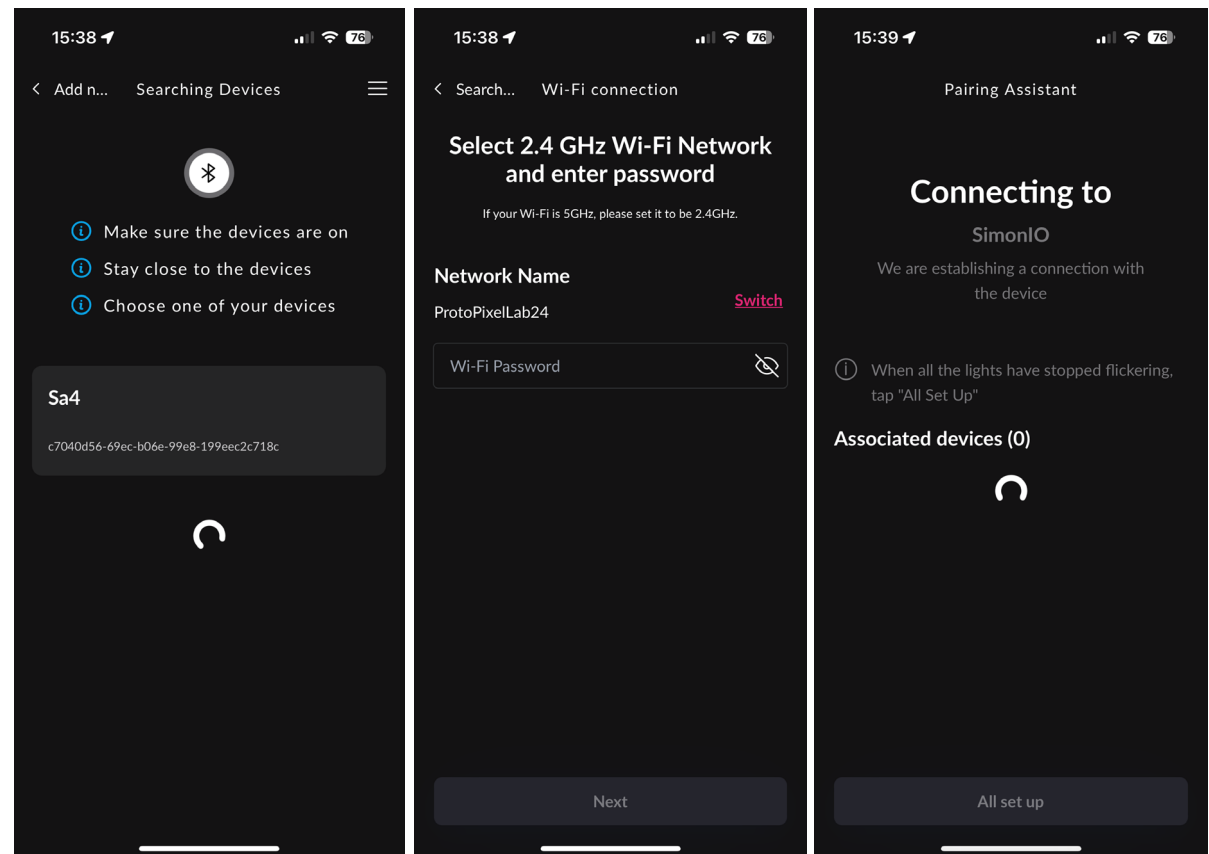

04

Remove Simon iO 270 from an installation

To remove a Simon iO270 button from an installation, follow these steps:

1. Open the ProtoPixel Project Tool.
2. Click on the button you want to remove.
3. In the inspector panel, locate the "Actions" section.
4. Look for the option "Remove element from installation" and click on it.

Then confirm that you want to delete that element from your installation.

Once deleted, you should see a confirmation message that lets you know the element is no longer part of the installation.

[More info about Simon iO 270 devices.](#)

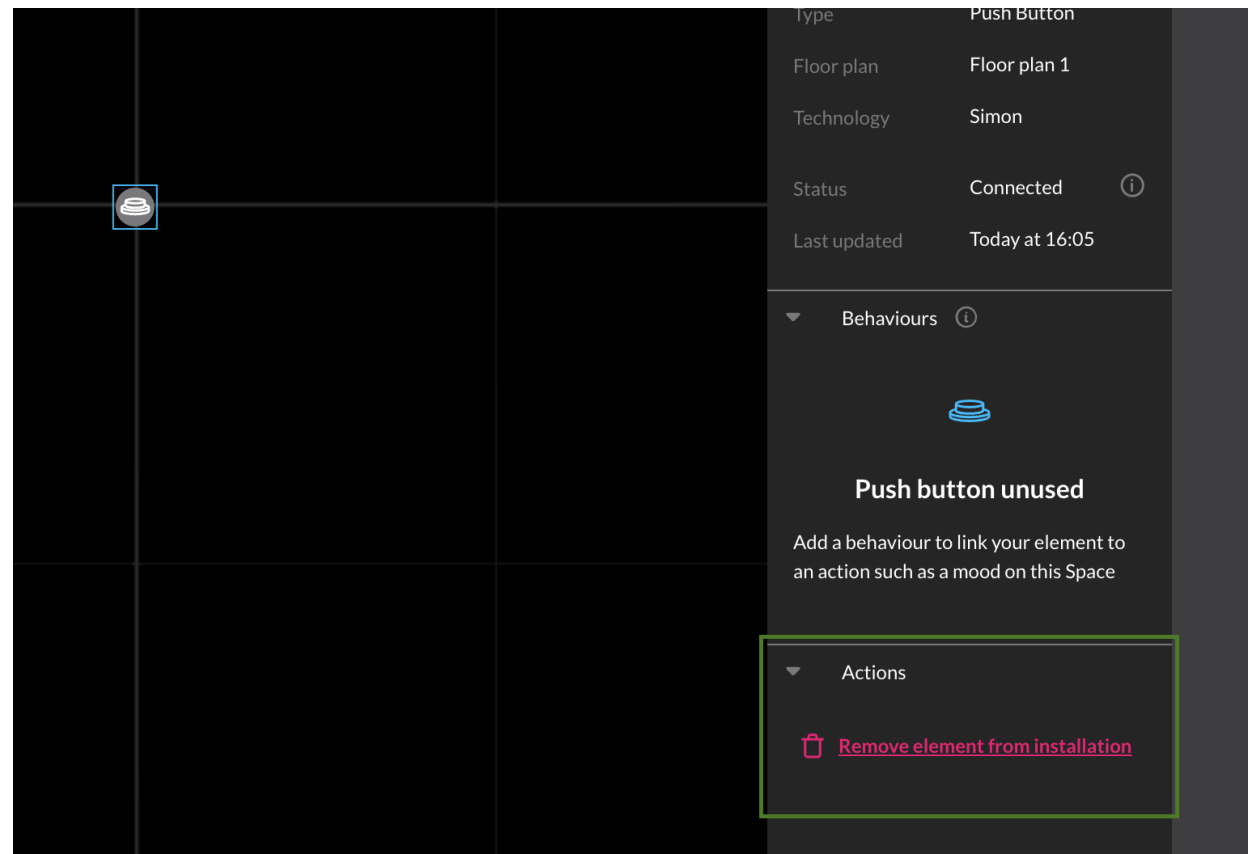

04

Project Tool with ProtoPixel Mapping Tool

Import ProtoPixel Mapping Tool's Projects

Having the opportunity of importing ProtoPixel Mapping Tool projects is key in order to interact and control SPI, DMX and other types of technologies. You can check-out ProtoPixel Mapping Tool's user guide [here](#).

Discover ProtoPixel Mapping Tool Files

Once you have Project Tool'd your ProtoPixel Mapping Tool project into the ProtoPixel Brain, navigate to the Discovery and Addressing section. Under ProtoPixel Mapping Tool, you will find the content that you designed using

Save your ProtoPixel Mapping Tool's project into the ProtoPixel Brain

You'll need to upload your ProtoPixel Mapping Tool project to the ProtoPixel Brain.

Interact with Fixtures from ProtoPixel Mapping Tool

Once you have your ProtoPixel Mapping Tool content visible and included, clicking on it will display all the available control options on the right panel. This includes the contents you have created and defined for the fixtures.

05 Elements Management

05	Elements management	
	Locate elements	21
	Place elements in the floorplan	21
	Control your luminaires	22
	Remove elements	23

05

Elements Management

Locate Elements

To locate an element in your physical installation, select the element you want to find. The right sidebar will automatically open. In the right sidebar, you will find the “Locate” button. Click on it, and your luminaire will start blinking.

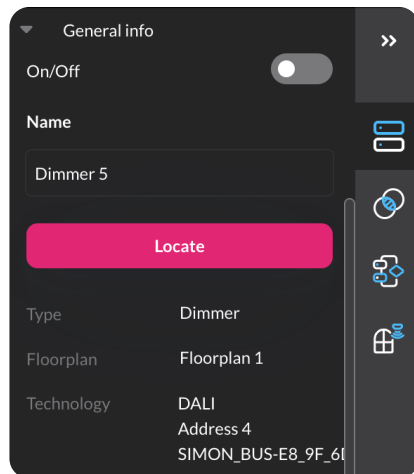

Place Elements on the Floorplan

To place elements onto your floor plan, you can simply drag and drop an element from the Elements list to the desired location on your canvas.

Unplace Element

You have the ability to remove elements from the floor plan that you have previously added. First, locate the element on the floor plan. Right-click on the element. Select “Remove from floor plan” from the menu. The element will be returned to the list of unplaced elements and you can place it back on the floor plan whenever you need to. Please note that if you remove an element that is part of a Space, it will also be removed from that Space.

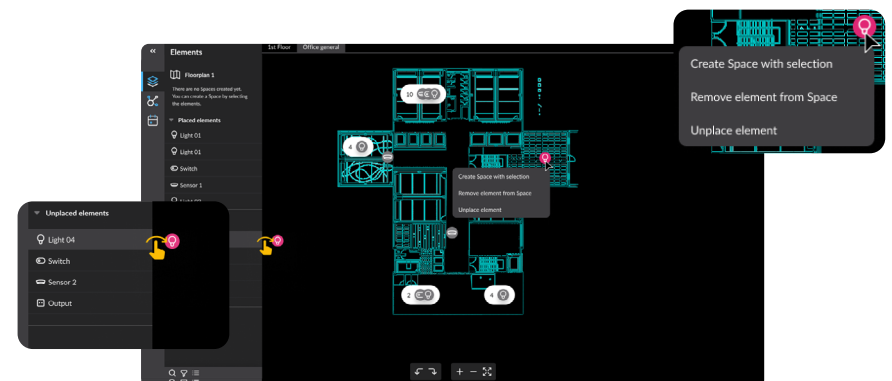

05

Control your Luminaires

General Info

To control a luminaire, you need to select it either from the floor plan or the Element's list. This action will automatically open the properties panel. In the properties panel, you will find the selected luminaire's capabilities and general information displayed. The following is the general information about the element displayed on the properties panel:

- Floorplan where it is placed
- Element type
- Status (Connected, Unreachable, Synchronizing)
 - Last Updated
 - Replace element action: more information in the **Replace Element Section**
- Technology information
 - Example: DALI, Dynamic Lighting (ProtoPixel Mapping Tool), etc.
 - Gateway
 - Bus name
 - Address (if DALI)

Actions

Options to delete, reset, or localize the element.

Capabilities Control

You will only see the selected luminaire's capabilities, which may include: Brightness, Color Temperature, OnOff.

Available Configurations

Minimum Level, Maximum Level, Fade Time.

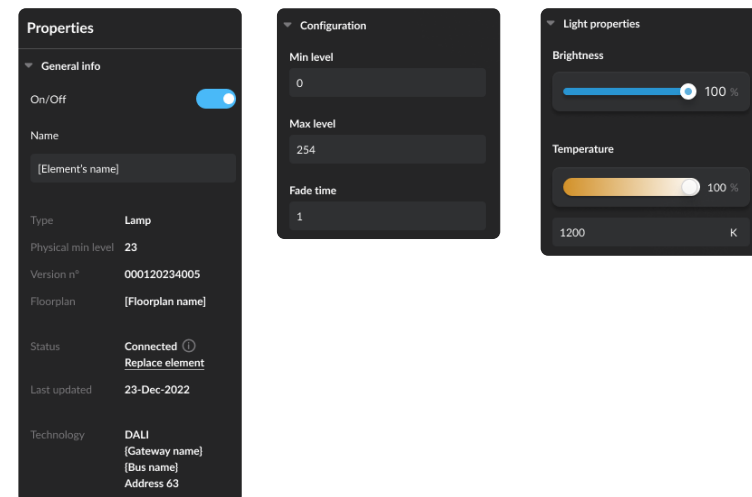

05

Removing Elements

How to delete an element

To delete an element from your installation, you need to click on it either in the elements list or on your canvas/floorplan. Next, click on the “Remove element from installation” option. A confirmation modal will appear where you will need to confirm the action by clicking on “Delete element”. Once you confirm, the element will be removed from your installation, including all the spaces and moods where it was previously added. Additionally, any behaviors created for that element will also be deleted.

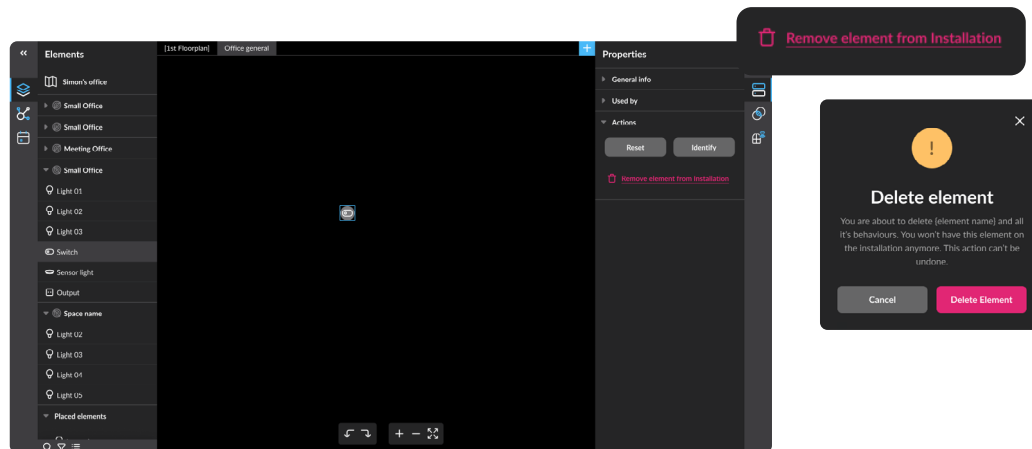

06 Managing Spaces

06	Manage Spaces	
	Create a Space	25
	Add Elements	
	Remove Elements	
	Add a Space within a Space	

06

Managing Spaces

Create a Space

With ProtoPixel Project Tool, you can create Spaces to organize your luminaires into groups of elements and control them collectively. To perform this action, you can select the elements directly from the floor plan or from the list of elements on the left. Hold down CMD/Ctrl and click on the item or group to select more than one. You can also drag on the floor plan to select elements placed within it. Once the selection is made, right-clicking will display the option to Create Space with the selection. A Space will be created, and you can double-click on the newly created space to change its name. To create a Space, all Space elements must be placed. Spaces can be accessed from the element's List menu in the Left Bar.

Add Elements

To add an element to a Space, simply drag and drop it from the Elements list onto the desired Space.

Remove elements from a Space

When you right-click on an element from the floor plan, you will see the options to edit the element, including the option to **Remove Element from the Space**. Alternatively, you can edit the elements of a Space by accessing the list of elements located on the left. Right-click on the name of the element, and you will see the option to **Remove Element from Space**. When you remove an element from a Space, that element will not be involved in any group action or mood that is executed, created, or edited within that space.

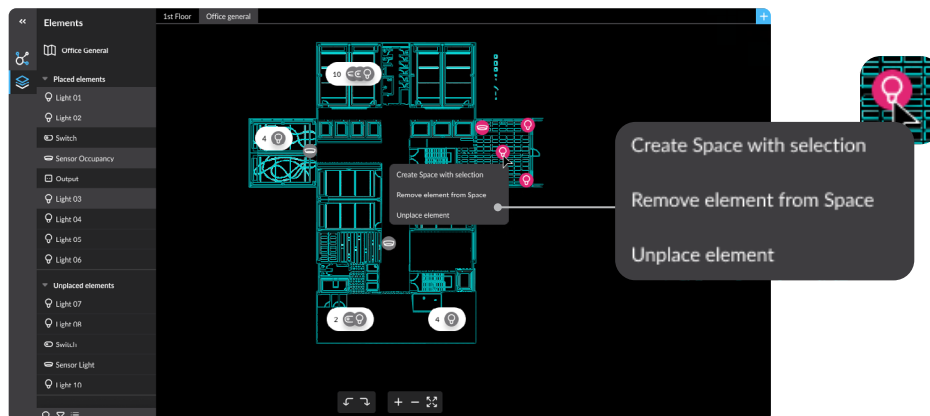

07 Moods

07	Moods	
	Creating a Mood	27
	Edit or delete a Mood	

07

Create a Mood

A Mood is a screenshot of the element's capabilities.

1. First, you need to configure all the brightness, color, and temperature, on all the elements of the Space you are creating the mood in.
2. Then, select the Space on the element's list menu: the Space properties menu will be displayed to your right. Select the Mood menu on the right. To select the Mood menu, navigate to the right side of the screen.
3. To create a new Mood, click on the "+" button next to "Moods". Then you'll be able to choose which elements of the Space will be part of the mood you are creating.
4. Put a name to the new mood and click on the "Save mood" button. This will take a screenshot of the current state of the luminaires you have selected.

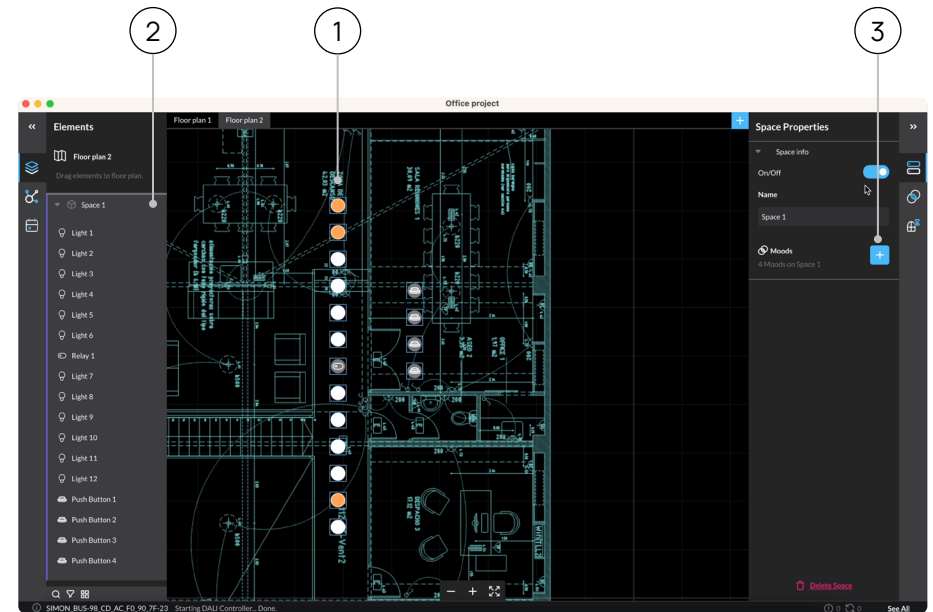

Applying a Mood

5. To apply a mood, navigate to the Moods menu and select the card of the desired mood.

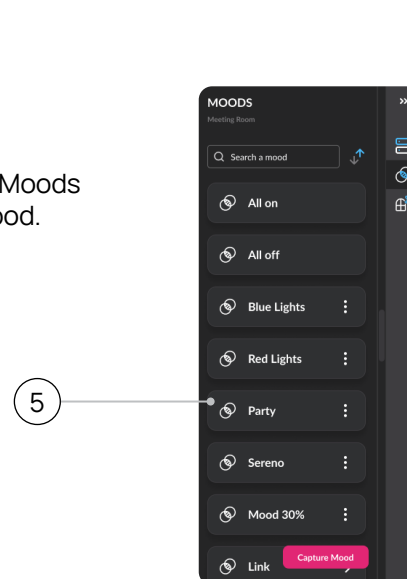

07

Edit or Delete a Mood

To edit or delete a mood, navigate to the Moods list. To access the Moods menu, select the Space where the mood is configured. Click on the Options icon (⋮) on the mood card. The options will be displayed.

Edit

Editing refers to updating the Mood configuration. When you click “Edit mood” you’ll be able to change the moods name. For editing how the mood is and adding / removing luminaires you need to click on the Edit button. When clicking on the Edit button, you’ll be able to select which elements are part of that mood.

Once you have all the elements as you need them, you can click on the “Update mood” button. That will replace the current status of the elements to create the new mood.

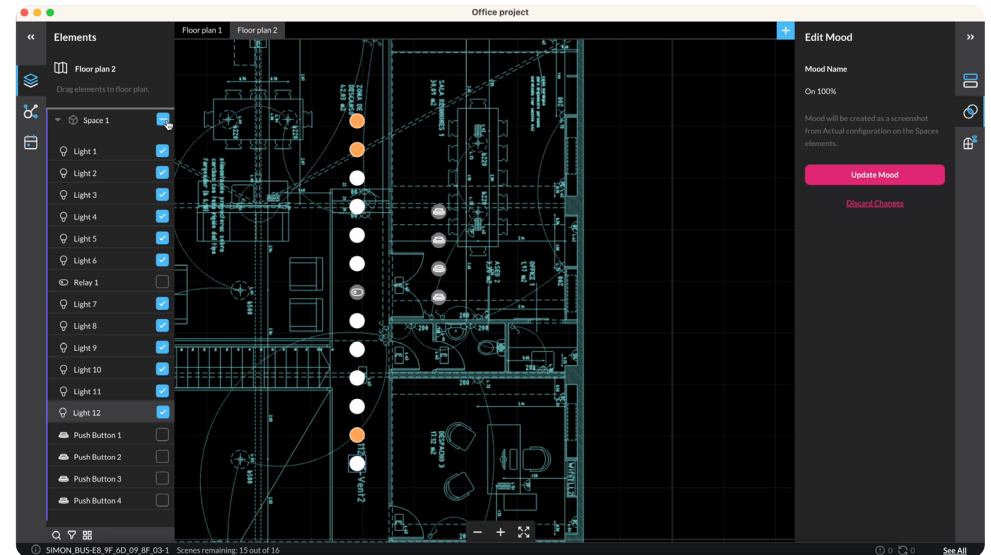
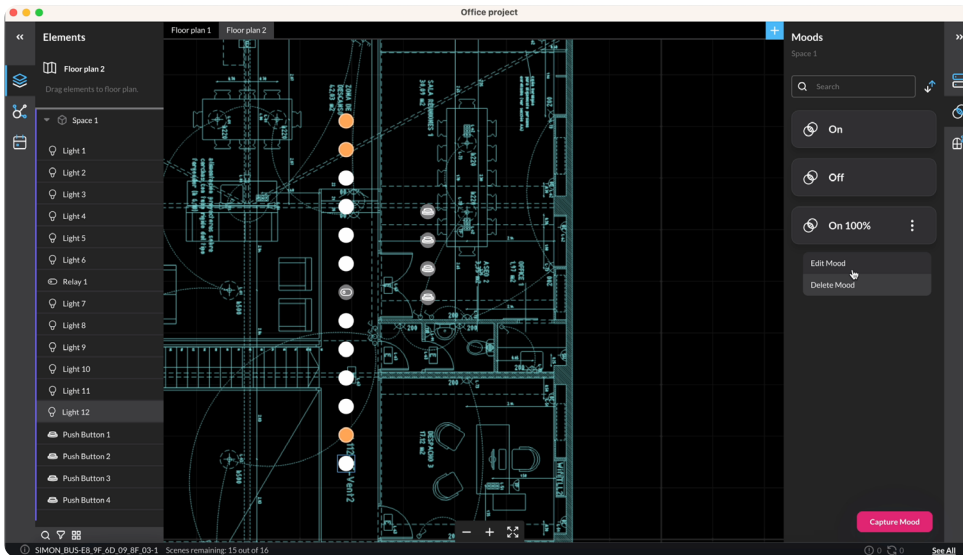

07

Delete

To delete a mood, click on “Delete” in the options panel. A modal will appear, asking you to confirm the deletion action.

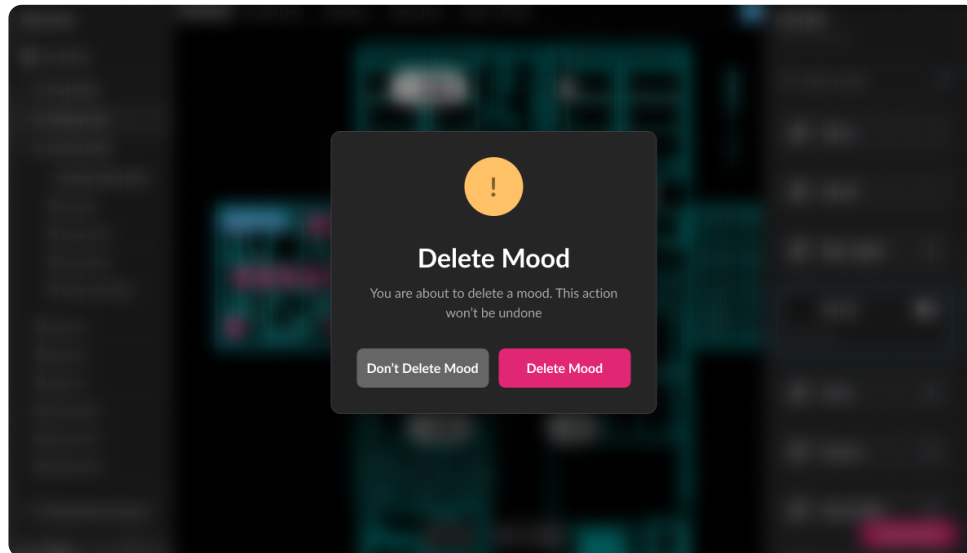

08 Behaviours

08	Behaviours	
	Create a behaviour for a Button	29
	Create a behaviour for a Occupancy Sensor	30

08

Behaviours

Create a Behaviour for a Button

Select a Push button from the elements list or the floor plan. Have in mind that it needs to be on a Space. Click on “Add behaviour” on the options panel. The “Create a Behaviour” panel will open, here you can see Logic conditional boxes that are connected. You can configure an “action” to be activated thanks to a trigger (“when”).

Selecting Actions

Select the event on the first card and the action you want to be triggered on the second card. Once you have selected the action you can save the behaviour and it will be showed on the Behaviours section of the Options panel. You will be able to see all the behaviours on the Push button Properties panel. To edit any Behaviour, click on the Behaviour card (they appear on the Push Button Properties Panel). You can't have more than one action per event type. For buttons, depending on the element you have, you can choose between:

- Short press: a quick press on the button
- Long press: holding the button down for a few seconds
- Release: when the button is released

Once you have selected the action you can save the behaviour and it will be showed on the Behaviours section of the Options panel. You will be able to see all the behaviours on the Push button Properties panel. To edit any Behaviour, click on the Behaviour card (they appear on the Push Button Properties Panel). You can't have more than one action per type of event.

A behaviour is the action that an element, such as a sensor or a button, triggers when it receives a command.

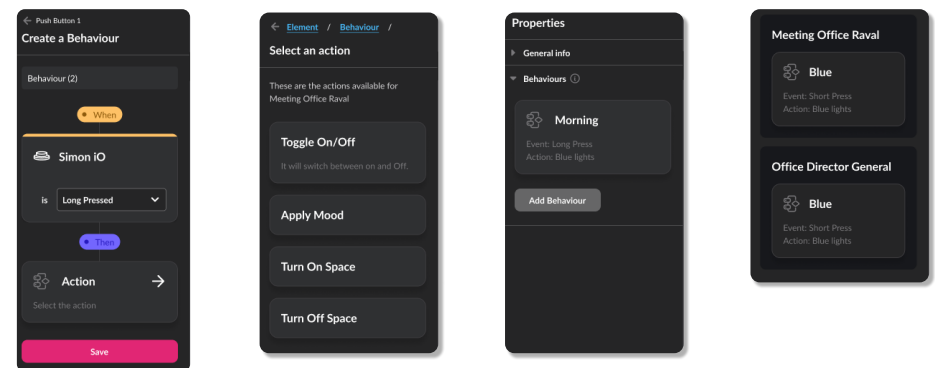
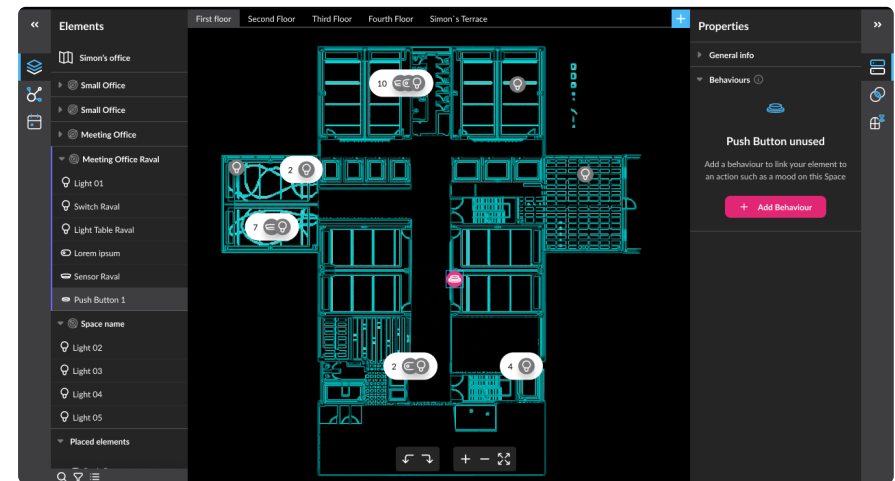

Create a Behaviour for an Occupancy Sensor

To create a behavior for an occupancy sensor, you need to select it either from the elements list or from the floorplan. Please keep in mind that the sensor needs to be included in at least one space. Next, click on the 'Add behavior' button. You have to select whether the behavior you are defining will occur when the room is occupied or vacant.

Then, choose the action that will be triggered, which can involve turning the space on or off, or applying a mood. If you choose a mood, you will need to select one from the moods you have created for that space. You can also define the idle value, which represents the state the space will assume after a certain period of no movement detection. Once you have defined all aspects of the behavior, click on Save. You should have now a fully configured behaviour.

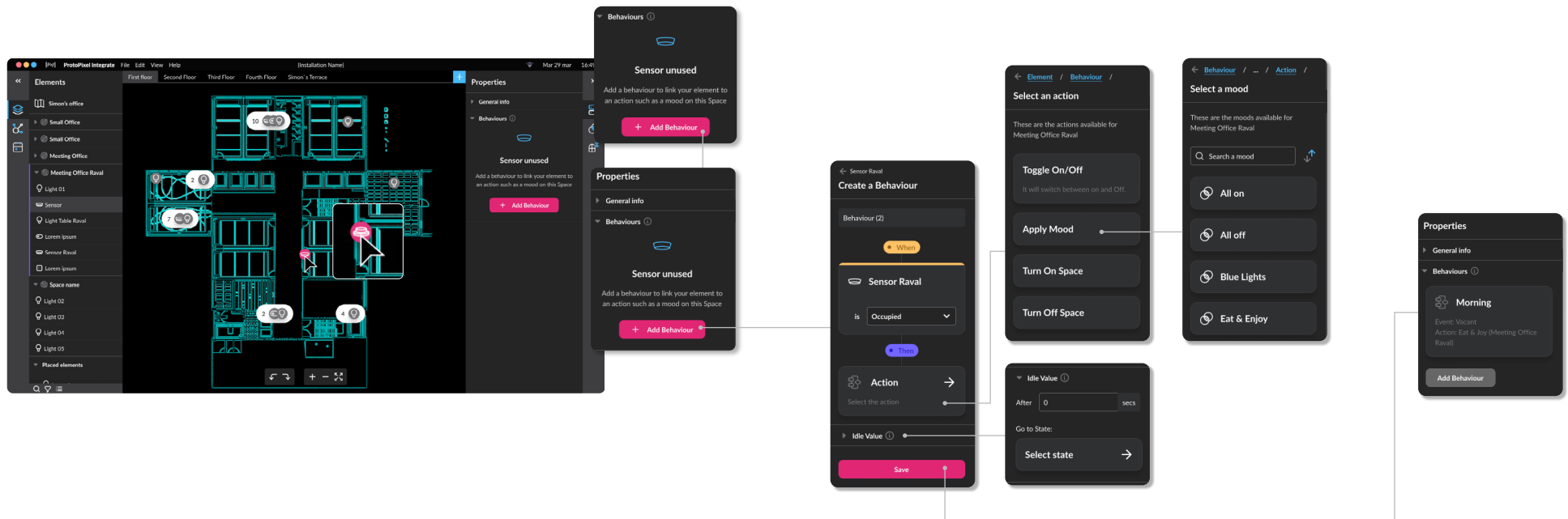

09 CLC

09	CLC	
	Activate the CLC for your Space	39
	Calibrate Sensor	
	Configure your CLC	40

09

CLC

Activate CLC on a Space

Our Constant Lighting Control (CLC) feature enables automatic control of lighting in your spaces. When CLC is activated in a space, the luminaires in that space will automatically adjust their brightness based on the natural light entering from outside, as measured by the sensors.

To activate CLC, follow these steps:

1. Make sure you have selected the desired space in the elements list.
2. Locate and click on the CLC icon in the inspector panel.

Note: in order to use the CLC, you need to have a luminosity sensor installed in the same space. When the CLC is active on a space, you will see an icon displayed over the space in the elements list.

3. To deactivate the CLC, simply turn it off in the inspector panel.

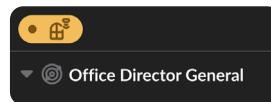

Calibrate the sensor for the first CLC use

When you first turn on the CLC in a space, you need to calibrate the sensor to align its measurements with the values obtained from a luxmeter used to measure the space.

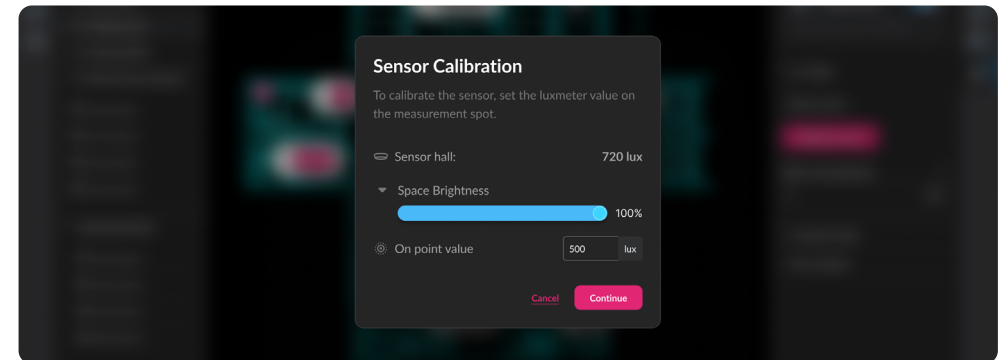

The first value you see is the real-time measurement of the sensor. You can manually adjust the brightness of the space to achieve a specific value and observe how it affects the luminaires. Next, enter the value displayed on the luxmeter at the desired location in the “On point value” input field. With this, you will link the sensor value with the “On point value” so that it changes accordingly and the CLC reaches the target value you set later. To repeat this action, click on the “Re-calibrate sensor” option in the inspector panel.

Re-Calibrate Sensor

09

Configure your CLC

Sensor selection

In your Space, you may have different sensors. To read the luminosity of the space, you need to select the sensor you want from the dropdown menu at the top of the inspector panel.

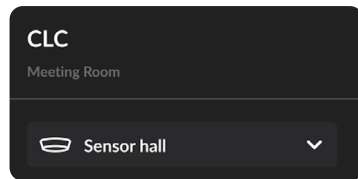

Set the target value

Once you have calibrated your sensor, you need to define the desired value for your space. This is the target value that the CLC's Project Tool will continuously try to reach. To define this value, enter the lux value in the "Desired value" input field in the inspector panel.

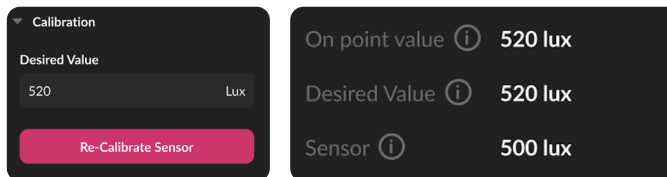

To ensure that the desired value is reached, you need to check that the "On point value" matches the "Desired value." Please keep in mind that sometimes the number of luminaires may not be sufficient to achieve high values.

Behaviour configuration

In this section in the inspector panel, you can deeply configure how your CLC must behave. In the "Idle value" section, you can specify the minimum percentage of brightness that the luminaires can have. This is important, for example, if you want to ensure that the luminaires are never completely turned off.

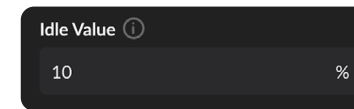

You can adjust the percentage of brightness variation for the luminaires to change at specific intervals, which allows for a smoother or faster experience. For instance, if you prefer smoother transitions, increase the amount of time and decrease the maximum variation. Conversely, if you need changes to be reflected quickly, opt for a larger variation every few minutes.



10 Scheduler

10	Scheduler	
	Configure your scheduler	32
	Create an event	33
	Scheduler viewing options	34

10

Configure your scheduler

When you first access the scheduler, you will be prompted to configure certain aspects in order to use it. The following items need to be defined:

- Time zone: This will ensure that Project Tool accurately manages your events by taking into account the appropriate time zone.
- Time and date format: Depending on your installation's region, you may prefer to display the date and time in a specific format.

Fill all data and click continue. This will automatically open the calendar view. To create an event on the scheduler, click on the “Create Event” button located at the top right corner of the screen. After clicking on the “Create Event” button, the Event Sidebar will appear. Write a name for your event in the designated field. Next, choose the date for your event by selecting the desired date from the date picker. Select the time for your event by choosing the appropriate hour and minute from the time picker.

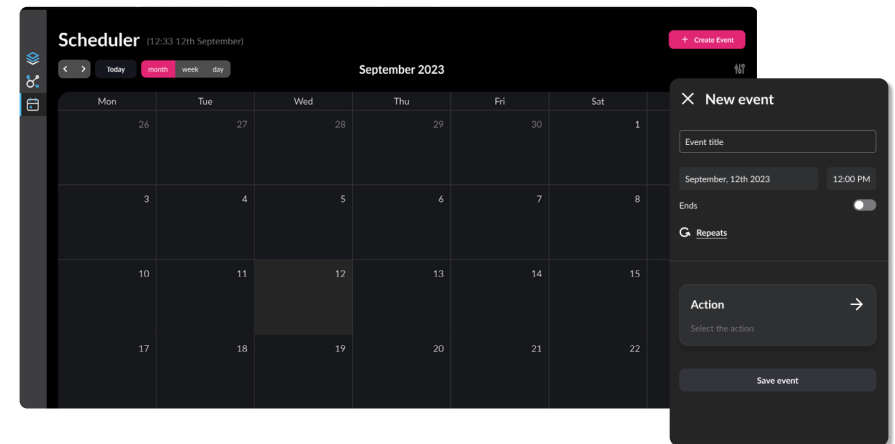
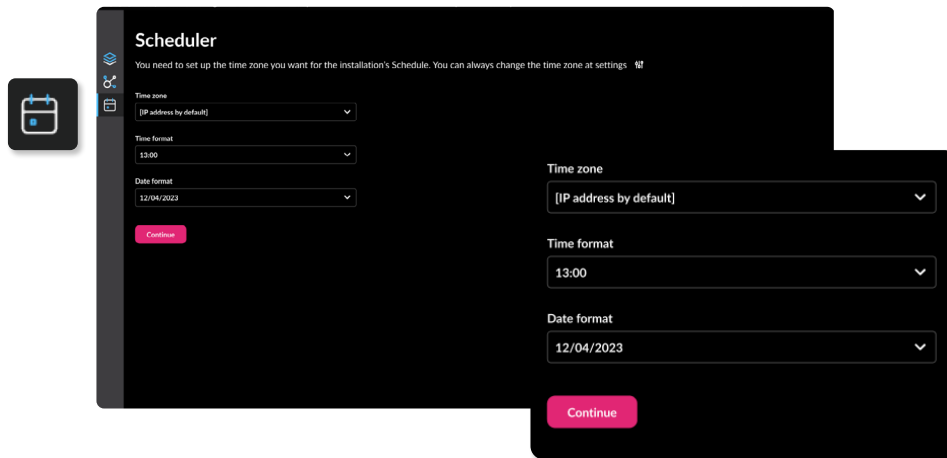

10

Configure your scheduler

You can set an end time for your event. If you don't choose any end time, the event will last until the next command or action is triggered. In order to set a end time, just turn on the "Ends" toggle and set the end time. If you need an event to be recurrent, you can click on Repeats link when editing it. A modal with the recurrence options will display.

Choose Action

In the Event Sidebar, click on the "Action" button. A window with all the available actions will pop-up, which includes: Apply Mood, Turn on Space, Turn off Space, and Enable CLC. Once you selected the desired action, click on "Save event".

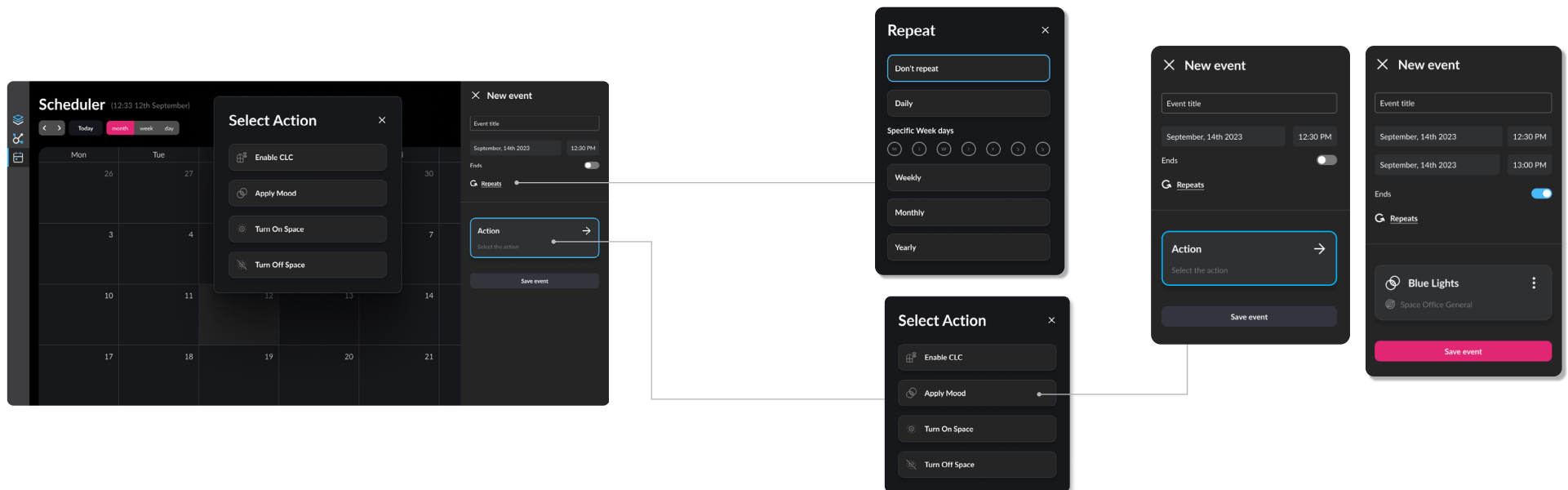

10

Edit or Delete Events

To edit or delete an event, locate the event on the scheduler view. Once you have identified the event, click on it to select it. A sidebar will appear on the right side of the screen, displaying event details and options. In the top right corner of the sidebar, you will see two icons. Delete event: Click on this icon to delete the selected event. Edit Event: Click on this icon to make changes to the selected event, such as modifying the name, date, time, or action associated with it.

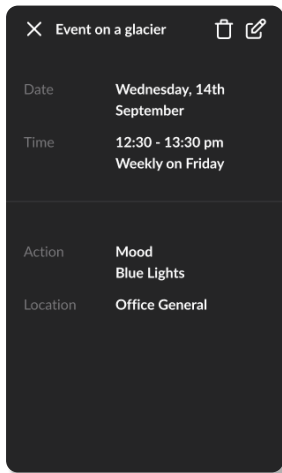

Scheduler Viewing Options: Month View

Month view displays all the events for the current month. You can navigate through months by using the arrows located at the top left. To configure the timezone: If you need to change the timezone after creating events, you can do so by clicking on the Filters icon in the timezone section.

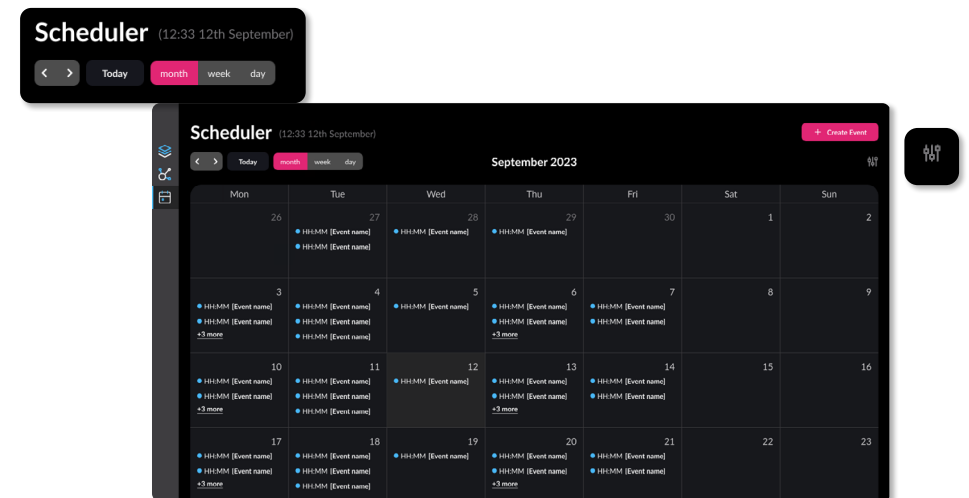

10

Week View

You can obtain a more detailed view of the scheduled events for the week by using the week view. You can navigate to different weeks by using the arrows.

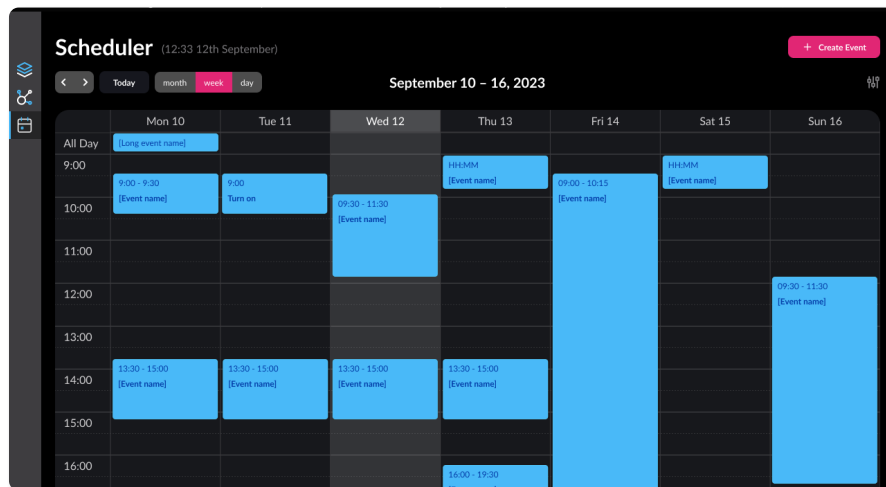

Day View

If you require a more comprehensive overview of the day, click on the day view. It will display the current day, and you can navigate through days by clicking on the arrows located at the top left. To configure the timezone: If you need to change the timezone after creating events, you can do so by clicking on the Filters icon in the timezone section.

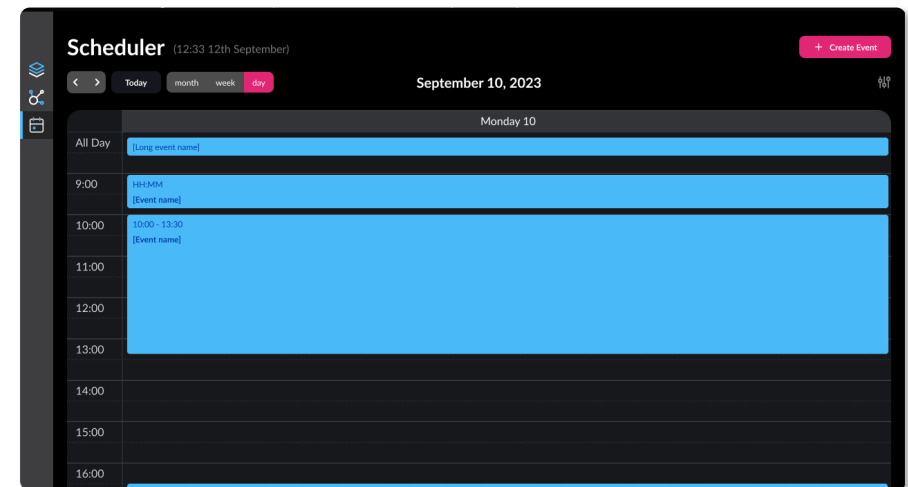

For more information
and inquiries, contact
us at protopixel.io

ProtoPixel Mapping Tool

User Manual

Contents

01	Mapping Tool Overview	42	03	Integrations	
	Concepts	43		DMX	66
	System Requirements	44		OSC	67
	System Architecture	44		Integration OSC and Events	68
	Install the Mapping Tool	45		UDP	69
	ProtoPixel Mapping Tool Licenses	46		Art-Net	69
	ProtoPixel Mapping Tool Interface	47			
02	Operational Guide				
	Workspace	52			
	Elements	52-53			
	Fixtures	54			
	Controllers	55-56			
	Content	57-59			
	Export Project	60			
	Recordings	61			
	Global Settings	62			
	Video Codecs	63			
	Spaces	64			

ProtoPixel Mapping Tool is designed to create functional and emotional moods for your spaces. A tool gives you all the power of high-level lighting software with all the benefits of a short learning curve.

01 Overview

01	Mapping Tool Overview	42
	Concepts	43
	System Requirements	44
	System Architecture	44
	Install the Mapping Tool	45
	ProtoPixel Mapping Tool Licenses	46
	ProtoPixel Mapping Tool Interface	47

01

Mapping Tool Overview

About

Design functional and emotional moods for your spaces. The ProtoPixel Mapping Tool gives you all the power of high-level lighting software with all the benefits of a short learning curve.

Features

- Offsite & Onsite mode (any device is needed to start a project)
- Content Library ready to be used
- Compatible with ProtoPixel Controllers as well as Art-Net.
- Lighting Content Preview
- Offline Backup

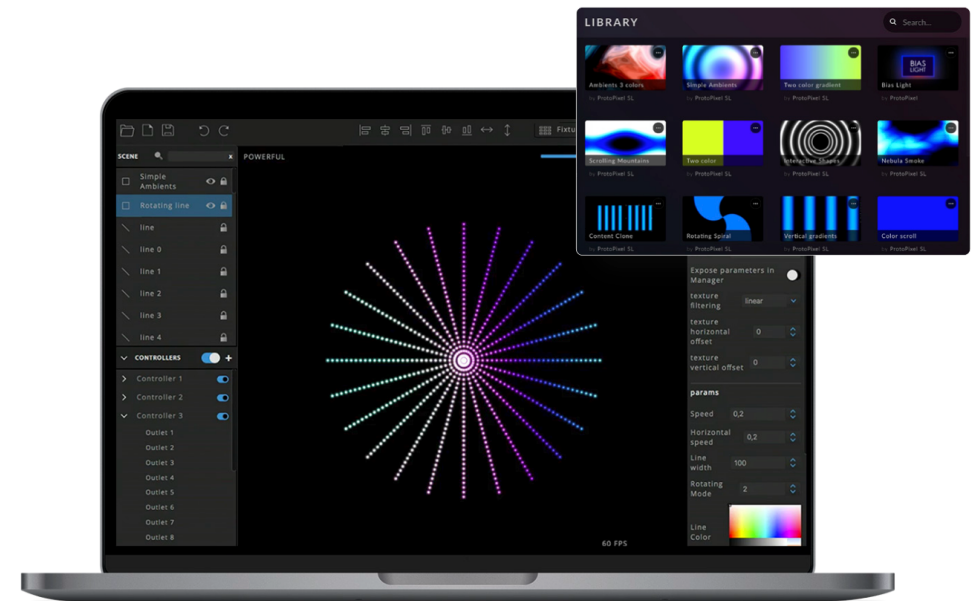

01

Concepts

How the ProtoPixel Mapping Tool Works

The ProtoPixel Mapping Tool is a pixel mapping software that helps you map visual content to physical lights in the real world. To do so, you will have to match places in your content to individual lights in the real world. Fortunately, this is very easy with the ProtoPixel Mapping Tool. Some key concepts are needed to understand and use the ProtoPixel Mapping Tool:

Light

In the ProtoPixel Mapping Tool we use Light to refer to a single controllable point of light, which can only have one color. A Light will typically be an addressable LED. We represent it as a point in space with a given color.

Content

Anything that produces color that can be mapped into lights is Content. Videos, images, and interactive animations are examples of Content.

Controller and Outlet

A Controller represents how the physical Fixtures are connected in a particular ProtoPixel Controller. Controllers have several Outlets representing the physical connections where Fixtures can be plugged. A Controller has to be paired to a Device to work in the real world.

Devices

Devices are how real-world ProtoPixel Controllers are represented in the software. Typically you would set up a Controller, fill in its Outlets, and then pair it to the physical Device. How fixtures are connected to the outlets of the Controller must

Project

All these elements are placed together in a Project. A Project can be saved in a file for later use.

01

System Requirements

System Requirements

- A computer with 4GB of RAM or more
- A ProtoPixel Brain Experience and/or a ProtoPixel Gate SPI Wired

Operating Systems

- macOS High Sierra 10.13 or later
- Windows 8 or later

System Architecture

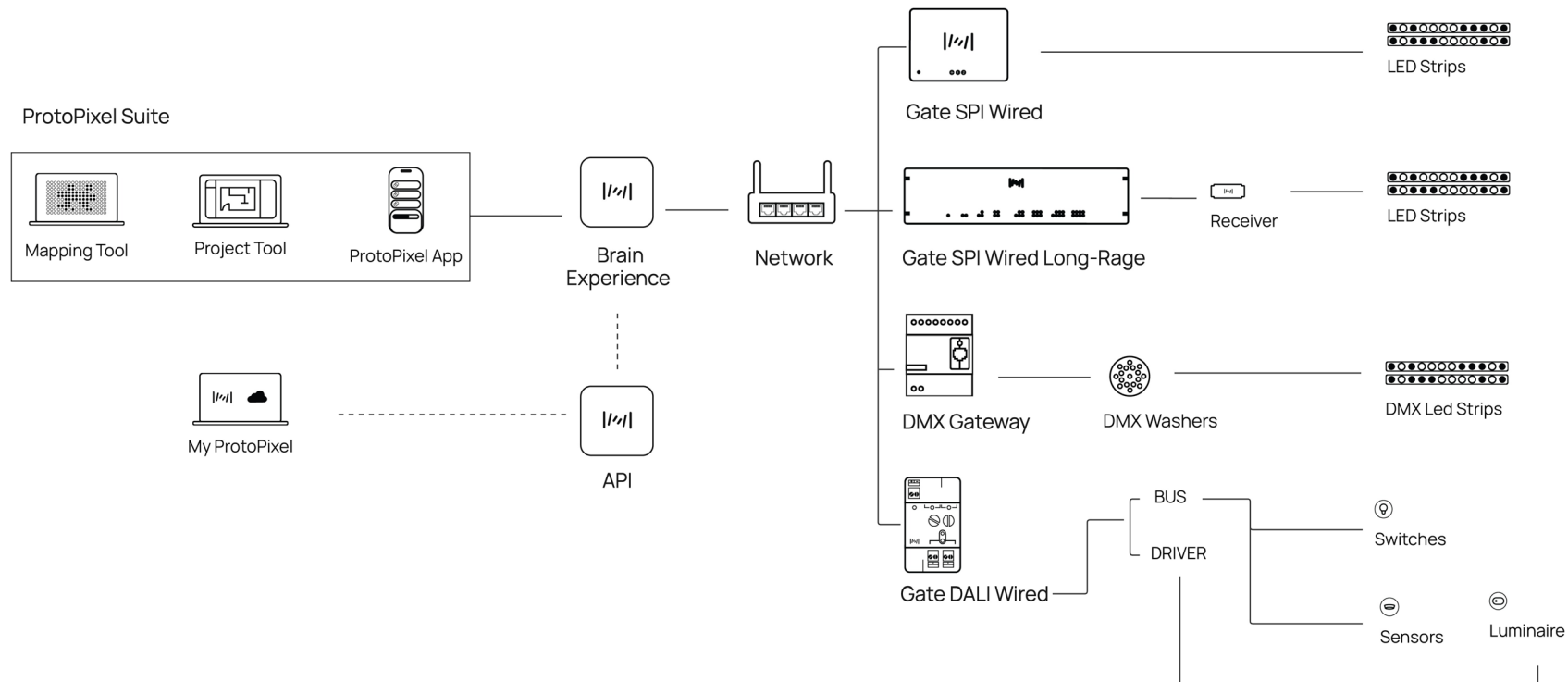

01

Install the ProtoPixel Mapping Tool

To install the ProtoPixel Mapping Tool, please follow the steps below:

- Start by downloading the ProtoPixel Mapping Tool from MyProtoPixel. This will ensure you have the latest version of the tool.
- If you are using a MacOS, locate the downloaded dmg file and double-click on it to unzip it. Once unzipped, open the dmg file and drag the ProtoPixel App into the Applications folder.
- For Windows users, simply double-click on the Installer file and follow the on-screen instructions to complete the installation process.
- After the installation is complete, find the ProtoPixel Mapping Tool icon on your MacOS desktop. Double-click on the icon to launch the application.
- On the first launch, you will be prompted to click on “Open” to start using the ProtoPixel Mapping Tool.

Please note that the above instructions are specific to MacOS and Windows operating systems. If you encounter any issues during the installation or launching process, refer to the official ProtoPixel documentation or seek assistance from their support team.

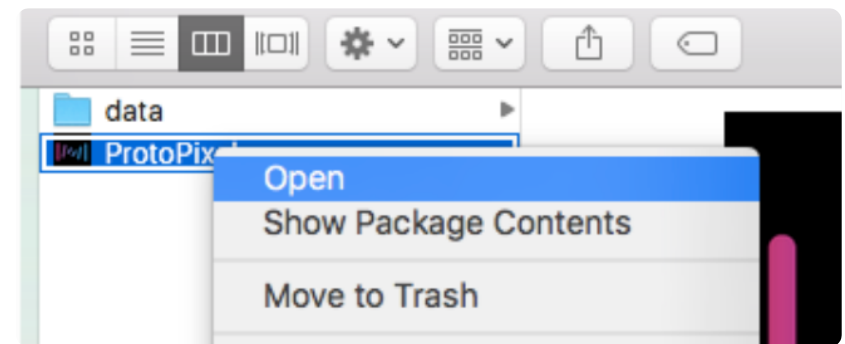

Important: The Mapping Tool must be opened by right-clicking on the application and choosing the Open option. Do not “double click” on the application.

01

ProtoPixel Mapping Tool Licenses

To install the ProtoPixel Mapping Tool, please follow the steps below:

- Access this website, also accessible by going to “Window > Subscription Account”.
- Enter the email address to which the license will be assigned and create a password for it.
- Click on the “Purchase now” button and follow the steps to complete the purchase.

Once you have purchased the license online, you need to add it to your computer. Ensure that you do not close the ProtoPixel Mapping Tool during this process.

To add your **license** to your computer, navigate to Window > Subscription Account.

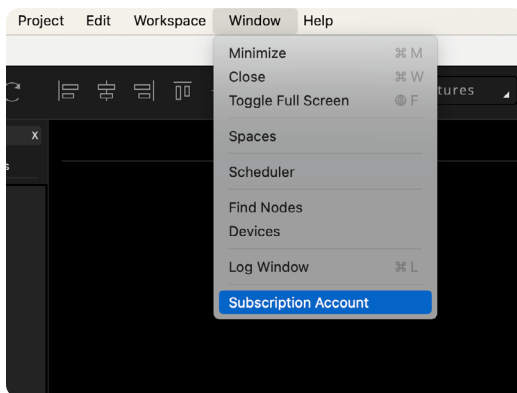

Activation Token

If you have an Activation Token, you need to add it to your navigation bar and go to “Help > Subscription” Next, add your email and the provided Token. Afterwards, click on “Activate”.

A license is tied to a single computer. Make sure you follow all these steps on the same computer you will be using the ProtoPixel Mapping Tool.

A web browser will open where you may be prompted to enter your email address. Please ensure that the email address you provide is the same one

used to purchase your license. To assign the license to this computer, click on the “Assign subscription to this Computer” option on the website.

Assign Subscription to this Computer

After clicking on the “Assign subscription to this Computer” button, a message will appear stating that “Your subscription is assigned to this

computer”. Now you can close and reopen the Mapping Tool to see the license reflected in the software.

Your subscription is assigned to this computer

01

ProtoPixel Mapping Tool Interface

The ProtoPixel Mapping Tool user interface is composed by several panels, showing the important information about your project.

- 1 Toolbar
- 2 Scene Panel
- 3 Controllers Panel
- 4 Inspector Panel
- 5 Workspace

Toolbar

The toolbar has many tools for fast access, these are:

- A Project operations: Open, Open Recent, New, Save
- B Undo, Redo.
- C Alignment Operations: Align Left, Horizontal Center, Right, Top, Vertical Center, Bottom, Spread Horizontally, Spread Vertically.
- D New Fixture Menu.
- E New Content Menu.
- F Global Properties.

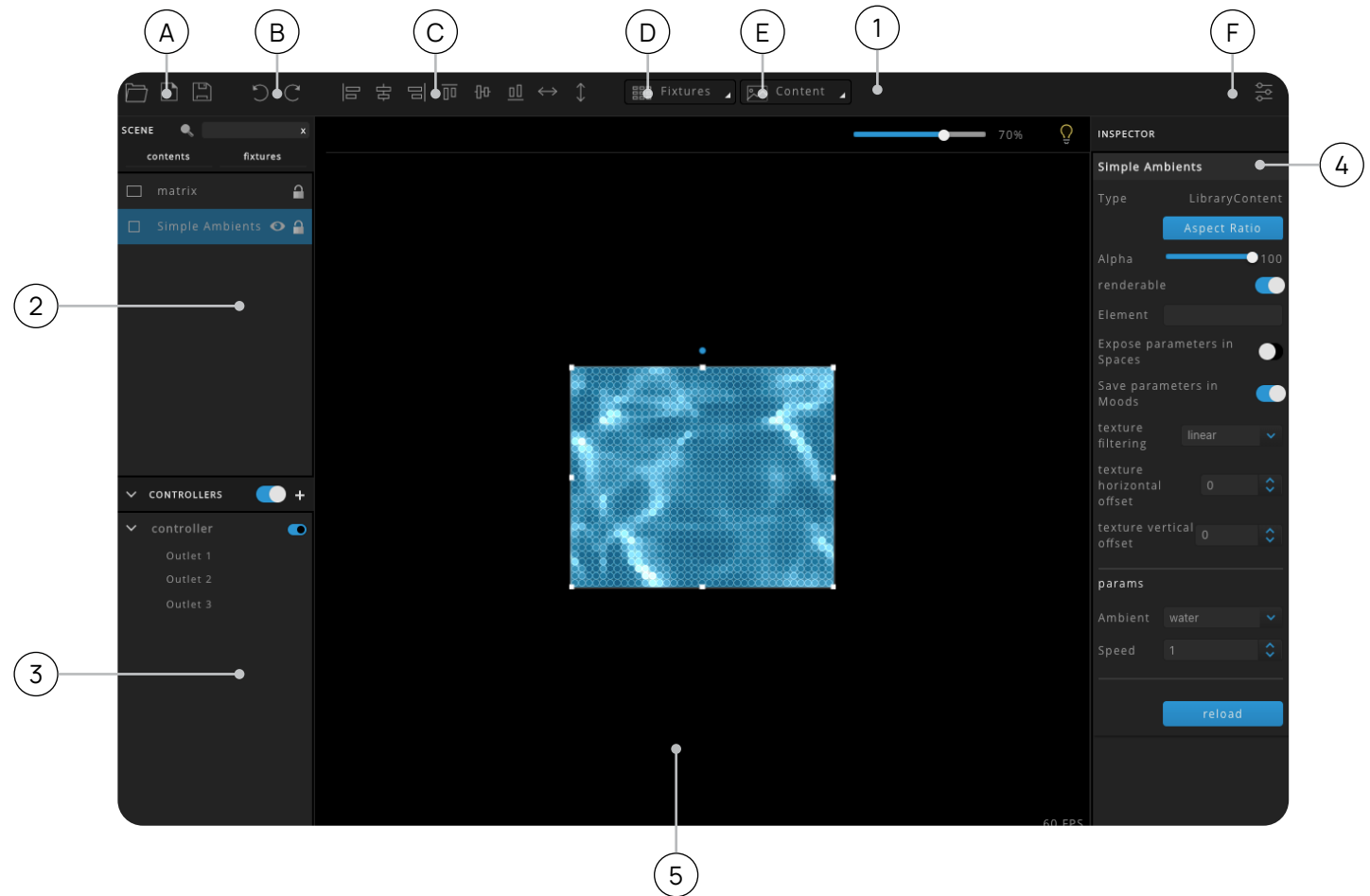

01

ProtoPixel Mapping Tool Interface

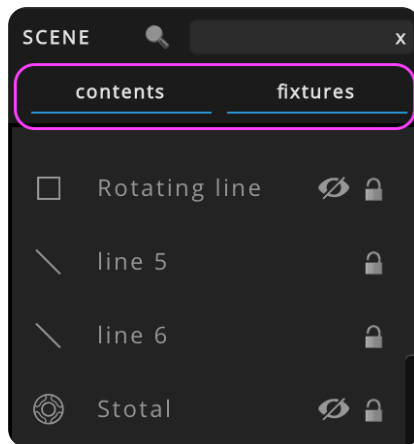

Scene Panel

The Scene Panel lists all Entities (Contents and Fixtures) in your Workspace. With it you can:

- Select an Entity (Click).
- Reorder an Entity (Drag & Drop).
- Center your Workspace on an Entity (Double-Click).
- Select multiple Entities (cmd + Click).
- Select a range of Entities (shift + Click).

- Make an Entity non-interactive (Click on the Entity's Lock icon).
- Hide a Content from your Workspace (Click on the Content's Eye icon).
- Filter Entities by Name (type on the top Search Box).

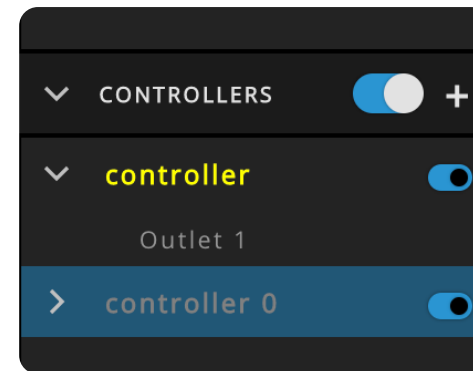

Controllers Panel

The Controllers Panel lists all Controllers and Outlets in your project. A Controller is just a group of Outlets. You can later bind a Controller to a real Device (see Creating and Configuring a Controller). In the Controllers Panel, you can:

- Add a new empty Controller (Click the + on the Panel title).
- Select a Controller or Outlets (Click it).

- Hide the Outlets of a Controller (Click its V).
- Deactivate a Controller to stop it from sending data (Click its switch).
- Deactivate all Controllers (Click the switch on the Panel title).
- Hide the Controller Panel (Click the v on the Panel title).

01

ProtoPixel Mapping Tool Interface

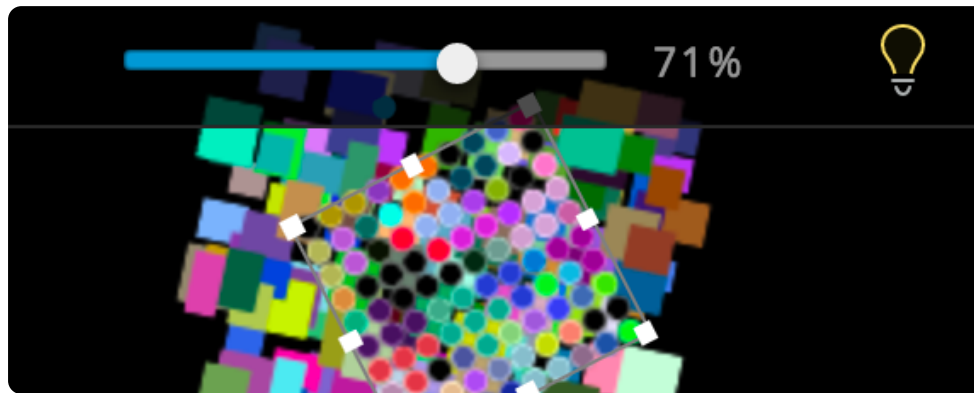

Workspace

In the Workspace, you can move and transform Fixtures and Contents by dragging them and using its handlers. Moving two fingers on your trackpad will move the workspace. You can zoom in or out of the Workspace with a pinch gesture or by pressing Cmd + scrolling up or down. The slider on the top right lets you manually control the zoom level and the bulb icon activates

and deactivates the *Preview Mode*. In *Preview Mode* all contents are hidden and the lights are rendered in a more realistic way. You will find an FPS indicator in the bottom right corner of the Workspace.

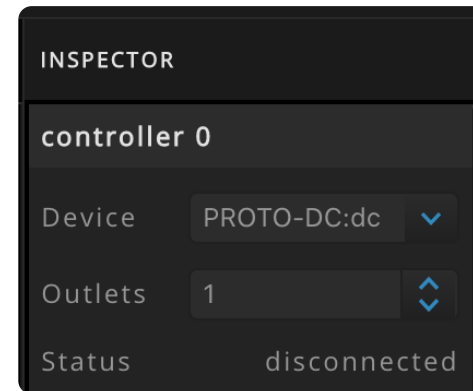

Inspector

This panel will show all the properties of the selected item. Some of those properties can be changed. The name of the selected item can also be changed just by editing it and pressing Enter. You can also cancel the edit by pressing Esc.

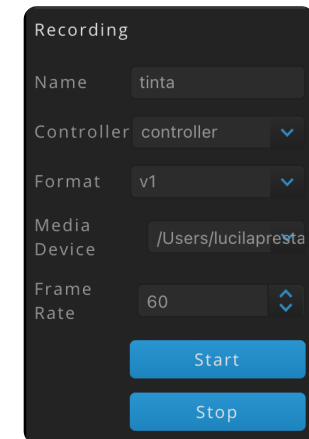

Recording Input

ProtoPixel Mapping Tool allows the recording of output for two different situations: For a single autonomous controller and for multiple standard ProtoPixel Controllers. These recordings are only useful if you have a ProtoPixel autonomous Controller or a ProtoPixel Player.

01

ProtoPixel Mapping Tool Interface

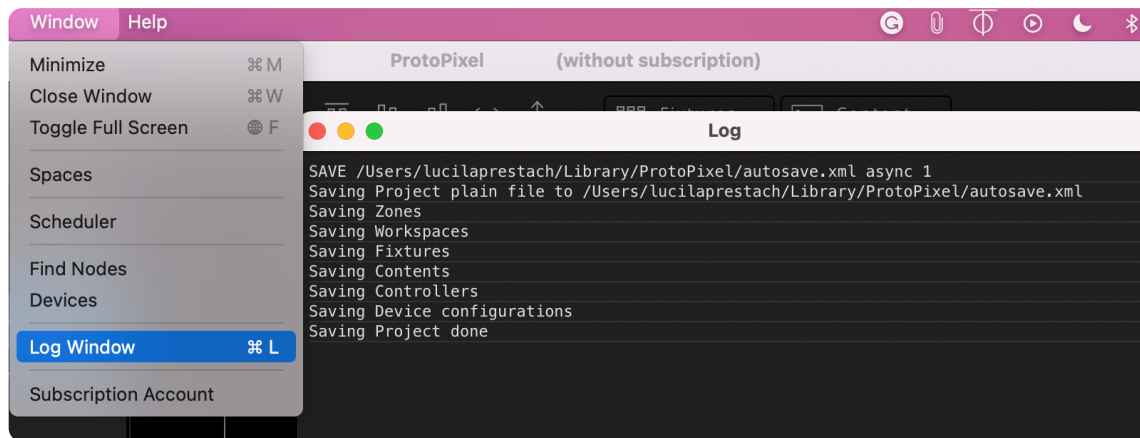

The Log Window

The Log Window shows messages from the ProtoPixel Mapping Tool Core. It is useful to debug scripting content. To show the log window go to **Window > Log Window** or press **Cmd+L**. Also, you can access the menu bar by selecting **Window > Log Window**

02 Operational Guide

02	Operational Guide	
	Workspace	52
	Elements	52-53
	Fixtures	54
	Controllers	55-56
	Content	57-59
	Export Project	60
	Recordings	61
	Global Settings	62
	Video Codecs	63
	Spaces	64

02

Workspace

Navigating the Workspace

As you may have noticed, items are created in the center of the Workspace. To navigate through it, you can right-click and drag, use the trackpad, or use the mouse wheel.

To zoom in and out, you can use the pinch gesture or hold the Ctrl key while scrolling vertically.

Elements

Selecting Workspace Elements Configuring and Manipulating an Element

You can select various Workspace Elements (such as Fixtures and Contents) to operate on them simultaneously. To initiate multiple selections, hold **cmd** and click on the elements you want to select, either on the Workspace or the Scene Panel. You can also use square-select by clicking and dragging the pointer across the

When you click on an element in the workspace, a Gizmo will appear, enabling you to transform it. To move an element, simply drag it using the pointer. To rotate it, drag the rotating handle (blue) (press shift to rotate in 15° steps). To scale it, drag one of the edges of the bounding box. To restore the aspect ratio, use the “Aspect Ratio”

button in the Inspector Panel. You can also select multiple elements to apply these operations collectively. When an element is selected, its properties are displayed in the Inspector Panel.

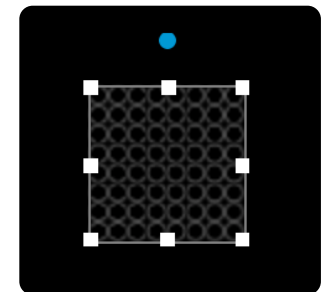

02

Elements

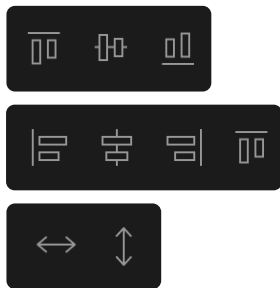

Aligning and Distributing Elements

To align the selected elements, you can use one of the Alignment and Distribution tools available in the menu. The alignment tools include vertical and horizontal alignment to the center and edges. The distribution tools work in both vertical and horizontal directions. Alignment is always performed using a selected group of elements as a reference.

Copying and duplicating Elements

You can copy and paste Elements using `cmd+C` and `cmd+V` key combinations, or using the menu (Edit > Copy and Edit > Paste). You can select any number of items to be copied. Pasted items will maintain the properties of the original, with a position offset. Pasted elements get automatically selected.

You can perform a quick copy-paste action by duplicating the items: `cmd+D` or Edit > Duplicate. performed using a selected group of elements as a reference.

02

Fixtures

Creating a Fixture

To create a new Fixture, click on the Fixture tool in the toolbar. This will display the different Fixture alternatives available for creation. Select the desired fixture type to create it. The new Fixture will appear selected in the Workspace. Alternatively, you can go to Workspace > New Fixture... > Fixture Type.

White Functions

There are several ways to extract the white component from an RGB color:

Mix: This method extracts the white component from the color and uses it as the white level. Pure white colors will not use the RGB components. Avoid using this function in a fixture without a white component, as it may result in incorrect colors.

Average: In this method, the white component is calculated as the average of the RGB components. This will yield slightly whiter colors.

Configuring Fixture Properties

In the inspector panel, you can adjust various properties that will affect how the fixture interprets colors in ProtoPixel. The first set of properties you will encounter are the ones that determine the size, shape, and connection of the fixture. These properties will differ depending on the specific fixture. Following that, you will find a series of parameters (table).

Color Modes

Here you select how the fixture should use the color from the content:

Original: The original RGB color is used.

Monochromatic: The intensity of the color is used to modulate the Base color.

Color: This will ignore the original RGB color altogether and use the Base Color directly.

Parameters Table

Parameter	Function
ON	Switch on and off output for this fixture
Level	Intensity of the light of the fixture
ProtoPixel Gamma Correction	Apply the gamma correction to the color
ProtoPixel Temporal Dithering	Try to get fine grade colors by adding some noise
ProtoPixel Double Points	Every pixel of the fixture should be sent twice
Force Channel	Select the address for DMX luminaries
Fixture Type	List of preset byte orders. This will depend on the fixture hardware
Custom Ordering	Define the ordering manually according to the fixture
White Function	Select average or mix
Color Mode	Select original, monochromatic, or color.
Base Color	Color used as a base, depending on the Color
Base Color Transition Time	Set up the transition time of the colors on dynamic contents
Transition Delay	Set up delay transition
Element / Zone	Name the fixture or group of fixtures

02

Controllers

Configuring Fixture Properties

To establish communication with real-world fixtures and send them lighting information, we need to establish a connection with the physical ProtoPixel Controller and specify how the fixtures are connected to the device. To add a controller, navigate to the Controllers Panel tab and click on the add icon. A new controller will be created with a default number of

outlets. You can modify the number of outlets in the Inspector.

There are two remaining actions:

- Adding fixtures to the outlets.
- Connecting the controller to a device. This will yield slightly whiter colors.

Adding Fixtures to Outlets

ProtoPixel Controllers do not have any information about how fixtures are connected to them. Therefore, we need to describe this information in the software. This allows the software to send the color information to the Controller in the correct order. To begin, we need to add the Fixture to the appropriate Outlet. To do this, first, select the Fixture. This will display its properties in the Inspector. Then, use the list to change the assigned

controller and outlet. If multiple fixtures are added to the same outlet, it is necessary to define the correct order in which they are connected to match the physical setup. To do this, select the *Outlet* in the Controller Panel and use the inspector to drag and rearrange the fixtures. As you select the outlet, a preview of its wiring will appear on the workspace. The starting point of the outlet is represented by a vertical line.

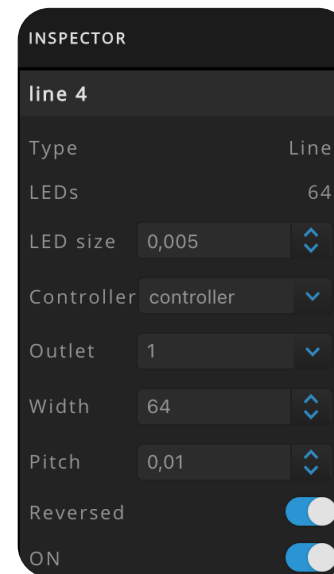

Inspector Window:
Line Section

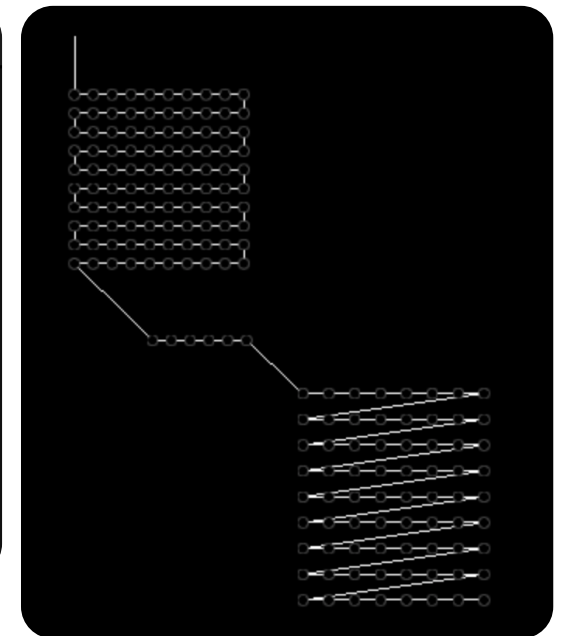

Outlet lines and order

02

Controllers

Connecting a Controller to a Device

Now that we have added Fixtures to Outlets, we need to connect your Controller to an actual Device. ProtoPixel Controllers are automatically detected when they are connected to the same network

as your computer. To pair a controller with one of the detected devices, select the Controller (this will display its properties) and choose the device from the list. This will also display the Device's properties in the Inspector.

Best Practices

👉 If the Controller cannot connect to the device, its name will appear in red in the Controller Panel until it reconnects again. You might be interested in the [ProtoPixel Gate SPI Wired Controller](#)

👉 You can modify certain parameters of the device in the inspector, depending on its capabilities. Refer to the table in the "Configuring the controller" section for more details.

👉 This typically occurs when the device is on a different subnetwork. Make sure that all controllers are on the same subnetwork as the computer running ProtoPixel Mapping Tool, and that the network mask allows for connectivity.

👉 Depending on the type of LEDs being used, you may need to adjust their RGB order to accurately represent colors in the real world. To do this, select all affected fixtures and modify their "PPx RGB ordering" property.

👉 Some Controllers may be inaccessible depending on their connection. While ProtoPixel Mapping Tool may be able to detect them, it may not be able to establish a connection or send data to them. In such cases, a warning with relevant information will be displayed next to their current IP property.



Inspector Window: Devices

02

Content

Adding Content

Now that we have Fixtures in the Workspace and have mapped them to real-world Fixtures, we can begin mapping content into them. To create content in the workspace, we can either press the Content menu in the Toolbar or use the Workspace > New Content... > Menu. We then select the desired type of content. Some content types require a file to function (such as images, videos, and scripts). These contents can be created by simply dragging the file directly into the workspace. As an example, we could create a Test content to verify if everything is set up correctly. This content consists of four squares of different colors rotating.

The ProtoPixel Mapping Tool includes several bundled types of content:

- 1 Color
- 2 Image
- Video
- 4 Script
- 5 Syphon
- 6 Test

****All types of content have an Alpha parameter that can be adjusted to change their transparency. Also, some contents can be configured to determine their alignment.**

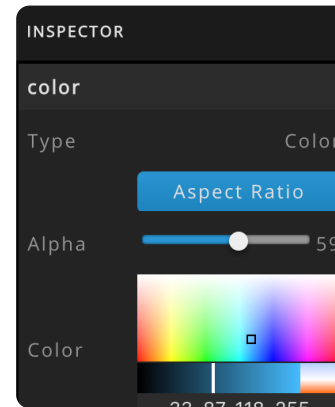

Inspector Window: Color

Parameter	Meaning
Texture Filtering	Define if the pixels should blur between them
Texture Horizontal	Offset move the content texture horizontally
Texture Vertical	Offset move the content texture vertically

Content Types: Color

This content defines a solid color. Adjust the color and temperature using the palette.

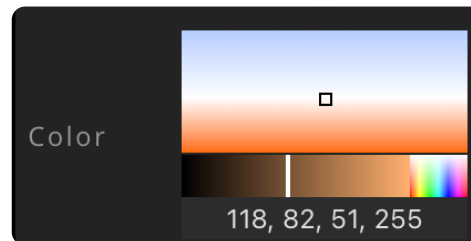

Tunable White

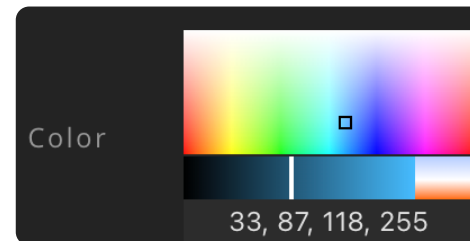

Full Spectrum

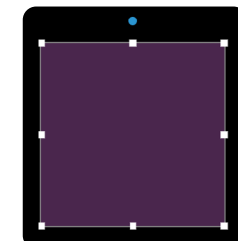

Color Content

02

Content

Image

This content imports an image. It supports the following formats:

.tiff

.jpg

.png

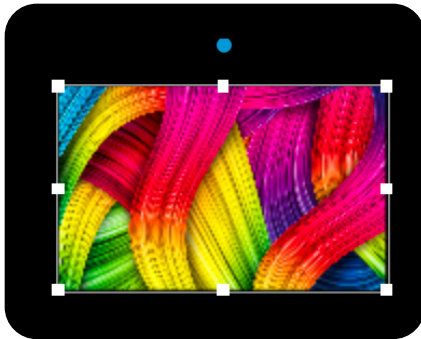

Video

Plays a video and maps it with the lights. The Inspector provides controls to play and stop the video. You can also adjust the volume and enable video looping.

Although the ProtoPixel Mapping Tool is capable of playing many video formats, we recommend using the following specifications:

- Container: mp4 (MPEG-4)
- Resolution: 1280x720 or lower
- Codec: H.264

You might find the [Video Codec Specifications](#) for Brain Experience article interesting.

More info on Video Codecs [here](#).

Test

This content provides a quick way to test content on fixtures. It consists of an endless video featuring rotating RGB squares of different colors.

You might be interested in [Content from Library](#)

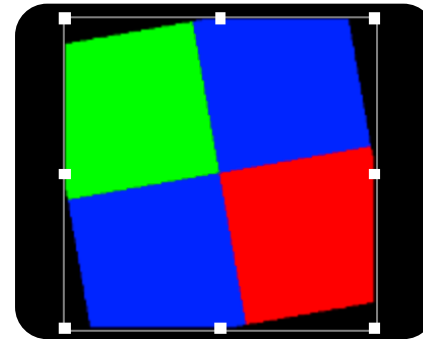

Syphon

You can create interactive content with software like Resolume, Modul8, Millumin, or even audiovisual interactive tools like Processing. By using Syphon technology, you can import image content directly into ProtoPixel. To do this in the ProtoPixel Mapping Tool, activate the Syphon output in the software you want to use. Next, add a Content > Syphon and select the desired application from the Source drop-down menu in the Inspector panel. The content will appear in the view and can be mapped like any other content.



02

Content

Script

The ProtoPixel Mapping Tool offers scripting capabilities for creating interactive content. It is based on the Python programming language and incorporates bindings to open Frameworks, a popular creative coding library. To familiarize yourself with ProtoPixel Scripts, you can refer to the provided examples. We recommend using a Python-aware editor, such as pyCharm or Sublime Text with Python addons, to edit the scripts externally. When saved, the programs will automatically reload in ProtoPixel.

Content Library

With the Mapping Tool, you have access to various default content options that you can customize to unleash your imagination and create incredible new content. [Library contents in the Mapping Tool.](#)

For advanced graphics generation in scripts, you can also use the pyOpenGL bindings after installing them separately.

To use a Script Content, create a python file and import it into the ProtoPixel Mapping Tool. Any errors in scripted programs will be displayed in the Log Window.

During execution, you can add various input elements to the properties of your script. The Mapping Tool will check for new inputs each time you click on the script content.

Shaders

- Make sure that you have installed a text editor on your machine.
- These instructions only work for the Mapping Tool (formerly known as Create) 3.0 or higher versions.

Steps for importing shaders into the ProtoPixel Mapping Tool

1. Go to the file package that you have downloaded, which contains the MappingTool.dmg file.

- Open the 'examples' folder.
- Open the 'scripting' folder.
- Drag and drop the [shader.py](#) Python file onto the Mapping Tool workspace canvas.

2. Select the shader you want to import.

- Go to your browser and search for the desired shader in a repository, such as [shadertoy](#)
- Identify the suitable shader for your project.
- Copy the code of the shader.
- Paste the code into a text code editor.
- Save the file on your machine.

3. Import your shader into the Mapping Tool:

- In the Mapping Tool, select the shader object (represented as a transparent square).
- From the inspector panel, select the shader path where you have stored the code.

Please ensure that your chosen shader does not have any external dependencies (check the information available in the 'iChannel'). If it does, it might not work in the Mapping Tool because those external sources would not be embedded.

02

Export Projects

How to Export

Once the project is correctly mapped in the ProtoPixel Mapping Tool, from the menu bar select the option **Project > Export** select a location, and name it. The file will be saved with the extension **.ppxexp**.

There are two kinds of projects:

1. The **bare project** is a file with a **.ppxproj** extension. It is created when you **save** a project. It only contains the essential parts for it to run on your computer.
- The **bundled** project is a file that also

has a **.ppxexp** extension. It is created when you **export** a project. It contains a bundle of all assets needed to run your project on any computer (videos, scripts, ...). this is the necessary extension to upload a project to the [Brain Experience](#).

To export your project go to Project > Export, or use cmd+E.

02

Recordings and ProtoPixel Gate

Create a Recording

In order to use the ProtoPixel Gate SPI Wired in standalone mode you will first need to make content for the ProtoPixel Gate SPI Wired to playback. This is done using the ProtoPixel Mapping Tool software which will allow you to make recordings that can be

Step 1: Lighting Fixtures

First define the fixtures in the Mapping Tool that you to control using the ProtoPixel Gate SPI Wired. Make sure that you have a controller with 1 or 2 outputs configured and that these are assigned to the corresponding fixtures that you intend to make the recording for. The recording will capture the all of the information generated when you run the content in the Mapping Tool and “hit record”, this includes which output

Step 2: Lighting Content

You can now start designing and laying out the content in the Mapping Tool that you wish to capture with the recording process.



If you think that you may upgrade your install to use a ProtoPixel Brain Experience to control the ProtoPixel Gate SPI Wired in the future now is a

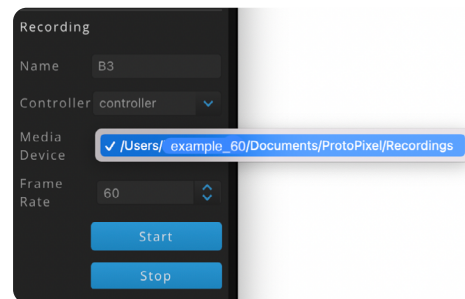

Step 3: Recording Storage

In the Mapping Tool inspector panel, you will find the Recording section. Here you need to define the recording name, select your controller and the path where you want to store the recording. By default, the recordings will be saved in your Documents folder (e.g. on Windows: C:\Users\YourName\Documents\ProtoPixel\Recordings) You will also need to define the frame rate you want your recording to be saved.



TIP: Add a suffix in your recording name indicating the frame rate (e.g. “_60fps”). It will be useful when uploading the file to your ProtoPixel Gate SPI Wired with the Player



Note that the format you must select from the recording panel in the Mapping Tool for the ProtoPixel Gate SPI Wired

Step 4: Record

Once you have completed steps 1, 2 and 3 you are ready to record. Run the content sequence that you wish to capture then click on the “Start” button to record. Once your content sequence is done you need to click the “Stop” button. Your recordings will be automatically saved to the path you defined in step 3.



A REC hint will appear in the Mapping Tool canvas (bottom right) to show when you are recording

02

Global Settings

There are several global settings that can be accessed through the global settings button in the Toolbar. Here is a description of each setting:

Installation Name	This name is used to notify you about expiring subscriptions or other installation-related events.	Process Sound	Enables sound processing for scripts that require it.
Starting Project	Specifies the path to a project that will automatically load when running the ProtoPixel Mapping Tool. This is useful for autonomous installations.	Global Framerate	Sets the maximum framerate for the entire application.
Async Rendering	It is recommended to keep this option activated for better performance. However, some older systems may actually perform better with it deactivated.	Preview Quality	Limits the quality of the preview in the ProtoPixel Mapping Tool. This does not affect the quality of the LED output, but reducing it can improve performance.
Autosave	The program periodically saves your work so that you can recover it in case of an outage or a crash. If a backup project is found when starting the application, a dialog will prompt you to recover it.	Manual Artnet Devices	Refers to recording output for a single SD Controller
		Scheduler	Refers to the scheduler feature.
		Recording	Refers to recording output for a ProtoPixel Player.

02

Video Codecs

To avoid issues with projects that include video files, ensure that the video codec is correct.

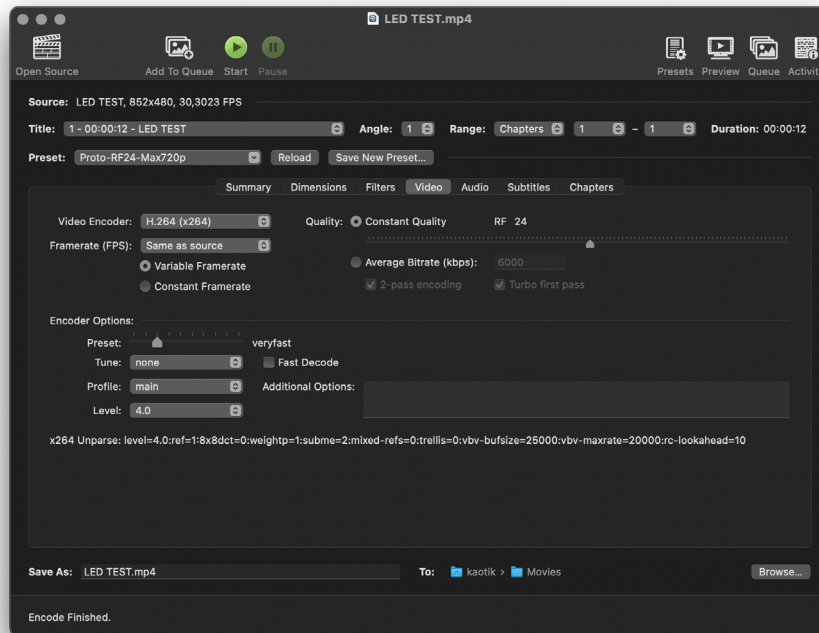

To use them, you will need to import the presets from the table in the following way:

1. Download the file [Proto-RF24-Max720p \(1\).json](#).
2. Open [Handbrake](#)
3. Click on 'Presets'.
4. Click on 'Import'.

You can find more info and resources [here](#).

If you are using the ProtoPixel Mapping Tool on Windows, a pop-up will appear during the installation process suggesting the installation of the codec pack. This message typically appears when you open the Mapping Tool for the first time on Windows, as well as when you try to add video content.

If you have ignored the suggestion, you can download the codec pack [here](#).

02

Spaces

Spaces is a tool for controlling various types of lighting, from everyday environments like offices to immersive experiences. This guide will demonstrate how ProtoPixel Spaces serves as the configuration co-pilot of the ProtoPixel platform, providing a control interface for users. It seamlessly integrates with other components of the suite, including the advanced lighting design software, ProtoPixel Mapping Tool, and the hardware device, ProtoPixel Brain Experience. Spaces enable users to create and manage their lighting environments, utilising moods, widgets, and rules for everyday use.

You can use Spaces as if you were on your mobile phone, but directly from the Project Mapping Tool. To do this, go to Window - Spaces. When Spaces is enabled, you will see an “Spaces enabled” alert at the bottom of the canvas, indicating that the installation is being controlled with Spaces.

For detailed instructions on how to use Spaces, please refer to its [manual](#).

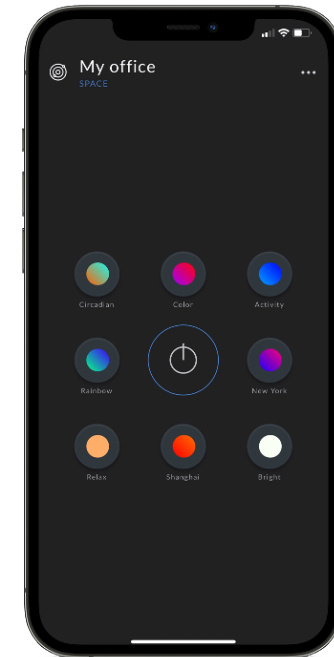

03 Integrations

03	Integrations	
	DMX	66
	OSC	67
	Integration OSC and Events	68
	UDP	69
	Art-Net	69

03

DMX

Property Editing

To use DMX, you have to edit the properties of the fixture (imagine that you created a fixture type line, which are several light points in a row). In the inspector, you will see the “PPx RGB Ordering” property.

This ordering must reflect the DMX channel distribution. In that case, the DMX fixture does not use a pre-defined layout, a custom layout can be created by selecting “Custom” in “PPx RGB Ordering”, and filling out the “custom ordering” section. For instance, if your fixture accepts 10 channels, the first one being intensity, the next 3 being RGB color, and the rest being various effects that you want to leave to 0, the layout would result in:

```
Int , R , G , B , 0 , 0 , 0 , 0 , 0 , 0
```

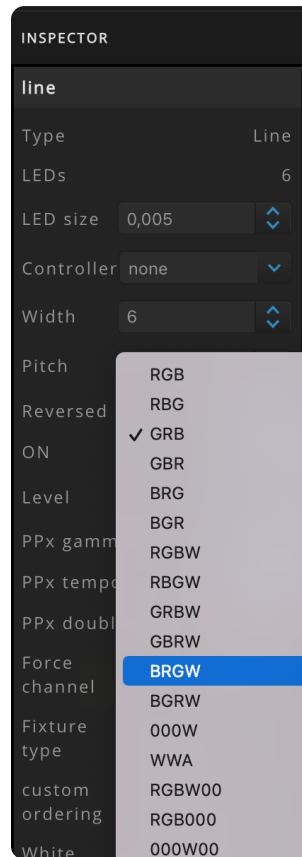

Possible Values for DMX

Letter	Meaning
R	Red
G	Green
B	Blue
C	Cyan
M	Magenta
Y	Yellow
W	White
< other >	Custom

If you add a symbol that is not on this table, it will be created a parameter on the panel, so you can manually change its value.

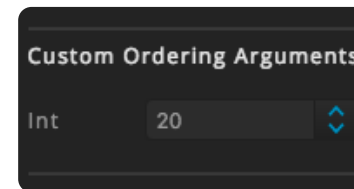

The fixture DMX addresses will start with 1 and accumulate the number of channels in the layout: 1,11,21,31 ... Then you have to connect with the Art-Net device (with DMX output);

first make sure it is connected to the network or directly wired to the computer. Add a Controller, and assign the fixture to outlet 1 (= universe 0). In the Controller, you should be able to select the Art-Net device from the menu. In case the Art-Net device is not detected, you can add manually one. Just follow the next section.

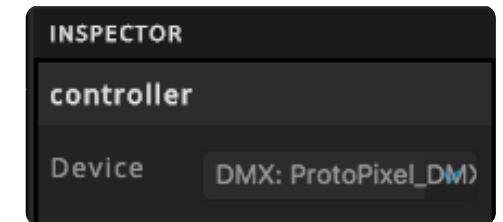

To manually add an Art-Net device first, you have to check that you have manual Art-Net devices activated in the Global Settings. Then, select the controller and assign to it the manual Art-Net device. This device works exactly the same as the Art-Net detected devices, with the difference that you can manually specify the IP address.

03

OSC Interface

Property Editing

ProtoPixel has a native Open Sound Control interface exposed in port 2345.

You can affect contents in your project by sending OSC messages to this port. The OSC address schema is like follows:

```
<type>/<name>/<param> <value>  
<type>/<name>/<param>
```

With those parameters:

<type> is the entity type, and at the moment it can only be Content.

<name> is the name of the entity

<param> is the parameter of the entity to be modified. You can see those parameter names by accessing the Content section in the WebApp.

<value> is the new value of the parameter. It can be omitted if the parameter is a button.



If the parameter is inside a parameter group, you can use / to separate the group from the parameter name. See the examples.

OSC Messages Examples

```
# enable content  
/Content/mycontent/enabled 1  
  
# disable content  
/Content/mycontent/enabled 0  
  
# play video content  
/Content/rainbow.mp4/params/play  
  
# stop video content  
/Content/rainbow.mp4/params/stop  
  
# change color for a color content (R, G, B, A)  
/Content/color/params/color 255 100 100 255
```

Custom OSC bindings

Custom OSC bindings are also available in scripts. See custom_osc.py example in the examples/scripting folder for more details.

03

Integration OSC & events

Controlling Standard Contents Getting all parameters from a Content

You can affect the contents in your project by sending OSC messages to this port. The OSC address schema is like follows:

```
</type></name></param> <value>  
</type></name></param>
```

With those parameters:

<type> is the entity type, and at the moment it can only be Content.

<name> is the name of the entity

<param> is the parameter of the entity to be modified. You can see those parameter names by accessing the Content section in the WebApp.

<value> is the new value of the parameter. It can be omitted if the parameter is a button.

```
CONTENT_NAME="color"  
curl -H "Content-Type: application/json" -X POST \\  
--data '{"command": "getSingleContent", "args": ["CONTENT_NAME"]}' \\  
<http://localhost:8181/api/v1/core/get?> | python -n json.tool  
  
{  
  "result": {  
    "name": "",  
    "color_levels": [  
      255,  
      255,  
      255,  
      255  
    ],  
    "enabled": true,  
    "lock_gui": false,  
    "params": {  
      "color": {  
        33,  
        87,  
        118,  
        255  
      }  
    }  
  },  
  "params_in_manager": false,  
  "projection_parameters": {  
    "height": 1,  
    "width": 1  
  },  
  "projection_type": "flat3d",  
  "python_script": "lib/program/color.py",  
  "reload": null,  
  "renderable": true,  
  "save_params_in_node": true,  
  "texture_filtering": "linear",  
  "texture_horizontal_offset": 0,  
  "texture_vertical_offset": 0,  
  "uid": "42f023060"  
}
```

Sending OSC to Custom Scripts

Inside a custom script, you can register an OSC endpoint like this:

```
@content.OSC("/acc")  
def acceleration(x, y, z):  
    """  
    This function handles OSC user input in address "/acc", with 3 arguments: x,y,z.  
    Use pl.OSC decorator to define handles like this. Multiple scripts can listen to  
    the same address simultaneously.  
    """  
    global color2  
    r = normalize(x)  
    g = normalize(y)  
    b = normalize(z)  
    color2 = ofColor(r, g, b)
```

Please take into account that if the number of arguments sent does not match the function signature, the message will not be delivered.

Sending events to Spaces

ProtoPixel Spaces can integrate with other elements such as presence sensors via its API. For more information consult [here](#).

03

UPD

Interface

There is also a UDP interface in port 2344. The mechanics are the same as the OSC Interface. The messages are composed like the following:

```
/<type>/<name>/<param> <JSON-encoded value>
```

For instance:

```
# enable content  
/Content/mycontent/enabled 1  
  
# change color for a color content (R, G, B, A)  
/Content/color/params/color [255 100 100 255]
```

Art-Net

Manual Art-Net Configuration

To manually add an Art-Net device, first check if you have enabled manual Art-Net devices in the Global Settings. Next, select the controller and assign the manual Art-Net device to it.



This device functions identically to the Art-Net detected devices, with the distinction that you have the ability to manually specify the IP address.

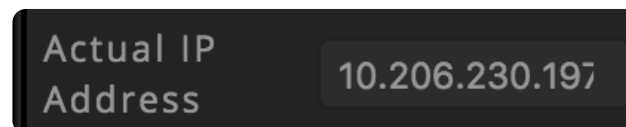

For more information
and inquiries, contact
us at protopixel.io